

Features:

- Exceptional conducted attenuation performance
- Excellent thermal stability
- Standard Mounting flange
- Designed with C14 and C20 connector
- Custom versions available on request
- Medical , safety versions are available

Applications:

- Power Systems
- Electronic Equipment
- Frequency convertors
- Stepper motor drives
- Rack mounting Equipment
- Medical equipment
- UPS/Inverters

DATASHEET
IEC INLET FILTER - MF300 Series

These series range of filters with IEC Inlet are designed to suppress undesirable electrical disturbances in Power Lines. They limit the amplitude of interfering voltages on AC powerlines and prevent them from propagating into or out of the filtered equipment

Performance Indicator:

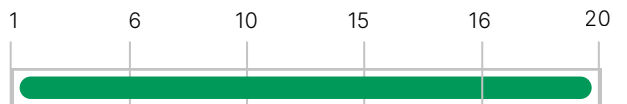
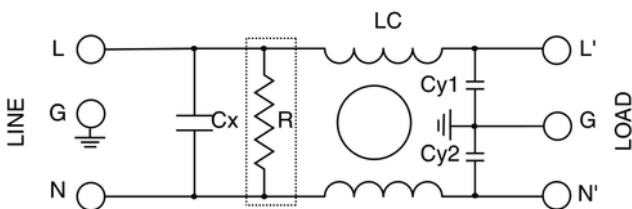
Rated Current (A):

Typical Circuit Diagram:



CY capacitors are not applicable for the medical version

Bleeder Resistor is optional

Technical Specifications:

Maximum Continuous Operating Voltage	: 250 VAC, 50/60Hz (UL Approval) 250 VDC
Operating Frequency	: DC to 400Hz
Current ratings	: 1A to 20A @40°C
High Potential test voltage	: L+N - G 2250VDC for 2 sec L-N 1450VDC for 2 sec
Overload Capability	: 135% of Rated current for 15 minutes
Design Corresponding to	: UL 60939-3, CSA 22.2 No.8-13 and IEC 60939 1&2
Flammability corresponding to	: UL 94 V-0
Temperature range	: -25°C to +100°C
Climatic Category	: 25/100/21

Ordering Information :

Standard Version : High Performance						
Model Number	Part Number	Current Rating @40°C(A)	Leakage Current @250 VAC/50Hz (mA)	Input Connector	Output Termination 	Min.Weight (g)
MF300-102-1-4	E100001-2	1	0.34	C14	-4	80
MF300-102-2-4	E100001-8	2	0.34	C14	-4	80
MF300-102-3-4	E100001-3	3	0.34	C14	-4	80
MF300-102-6-4	E100001-4	6	0.34	C14	-4	80
MF300-102-10-4	E100001-5	10	0.34	C14	-4	80
MF300-102-15-4	E100001-6	15	0.34	C14	-4	80
MF300-102-16-4	E113091-1	16	0.34	C20	-4	120
MF300-102-20-4	E113092-1	20	0.34	C20	-4	120
MF300-502-1-4	E113093-1	1	0.34	C14	-4	80
MF300-502-2-4	E113094-1	2	0.34	C14	-4	80
MF300-502-3-4	E113095-1	3	0.34	C14	-4	80
MF300-502-6-4	E113096-1	6	0.34	C14	-4	80
MF300-502-10-4	E113097-1	10	0.34	C14	-4	80
MF300-502-15-4	E113098-1	15	0.34	C14	-4	80
MF300-502-16-4	E113099-1	16	0.34	C20	-4	120
MF300-502-20-4	E113100-1	20	0.34	C20	-4	120

Safety Version : High Performance						
Model Number	Part Number	Current Rating @40°C(A)	Leakage Current @250 VAC/50Hz (mA)	Input Connector	Output Termination 	Min.Weight (g)
MF300-102S-1-4	E113111-1	1	0.16	C14	-4	80
MF300-102S-2-4	E113112-1	2	0.16	C14	-4	80
MF300-102S-3-4	E113113-1	3	0.16	C14	-4	80
MF300-102S-6-4	E113114-1	6	0.16	C14	-4	80
MF300-102S-10-4	E113115-1	10	0.16	C14	-4	80
MF300-102S-15-4	E113116-1	15	0.16	C14	-4	80
MF300-102S-16-4	E113117-1	16	0.16	C20	-4	120
MF300-102S-20-4	E113118-1	20	0.16	C20	-4	120
MF300-502S-1-4	E113119-1	1	0.16	C14	-4	80
MF300-502S-2-4	E113120-1	2	0.16	C14	-4	80
MF300-502S-3-4	E113121-1	3	0.16	C14	-4	80
MF300-502S-6-4	E113122-1	6	0.16	C14	-4	80
MF300-502S-10-4	E113123-1	10	0.16	C14	-4	80
MF300-502S-15-4	E113124-1	15	0.16	C14	-4	80
MF300-502S-16-4	E113125-1	16	0.16	C20	-4	120
MF300-502S-20-4	E113126-1	20	0.16	C20	-4	120

Medical Version : High Performance						
Model Number	Part Number	Current Rating @40°C(A)	Leakage Current @250 VAC/50Hz (µA)	Input Connector	Output Termination 	Min.Weight (g)
MF300-102M-1-4	E100998-2	1	0	C14	-4	80
MF300-102M-2-4	E100998-8	2	0	C14	-4	80
MF300-102M-3-4	E100998-3	3	0	C14	-4	80
MF300-102M-6-4	E100998-4	6	0	C14	-4	80
MF300-102M-10-4	E100998-5	10	0	C14	-4	80
MF300-102M-15-4	E100998-6	15	0	C14	-4	80
MF300-102M-16-4	E113101-1	16	0	C20	-4	120
MF300-102M-20-4	E113102-1	20	0	C20	-4	120
MF300-502M-1-4	E113103-1	1	0	C14	-4	80
MF300-502M-2-4	E113104-1	2	0	C14	-4	80
MF300-502M-3-4	E113105-1	3	0	C14	-4	80
MF300-502M-6-4	E113106-1	6	0	C14	-4	80
MF300-502M-10-4	E113107-1	10	0	C14	-4	80
MF300-502M-15-4	E113108-1	15	0	C14	-4	80
MF300-502M-16-4	E113109-1	16	0	C20	-4	120
MF300-502M-20-4	E113110-1	20	0	C20	-4	120

Standard Version : Very High Performance						
Model Number	Part Number	Current Rating @40°C(A)	Leakage Current @250 VAC/50Hz (mA)	Input Connector	Output Termination 	Min.Weight (g)
MF300-103-1-4	E113127-1	1	0.34	C14	-4	80
MF300-103-2-4	E113128-1	2	0.34	C14	-4	80
MF300-103-3-4	E113129-1	3	0.34	C14	-4	80
MF300-103-6-4	E113130-1	6	0.34	C14	-4	80
MF300-103-10-4	E113131-1	10	0.34	C14	-4	80
MF300-103-15-4	E113132-1	15	0.34	C14	-4	80
MF300-103-16-4	E113133-1	16	0.34	C20	-4	120
MF300-103-20-4	E113134-1	20	0.34	C20	-4	120
MF300-503-1-4	E113135-1	1	0.34	C14	-4	80
MF300-503-2-4	E113136-1	2	0.34	C14	-4	80
MF300-503-3-4	E113137-1	3	0.34	C14	-4	80
MF300-503-6-4	E113138-1	6	0.34	C14	-4	80
MF300-503-10-4	E113139-1	10	0.34	C14	-4	80
MF300-503-15-4	E113140-1	15	0.34	C14	-4	80
MF300-503-16-4	E113141-1	16	0.34	C20	-4	120
MF300-503-20-4	E113142-1	20	0.34	C20	-4	120

Safety Version : Very High Performance						
Model Number	Part Number	Current Rating @40°C(A)	Leakage Current @250 VAC/50Hz (mA)	Input Connector	Output Termination 	Min.Weight (g)
MF300-103S-1-4	E113159-1	1	0.16	C14	-4	80
MF300-103S-2-4	E113160-1	2	0.16	C14	-4	80
MF300-103S-3-4	E113161-1	3	0.16	C14	-4	80
MF300-103S-6-4	E113162-1	6	0.16	C14	-4	80
MF300-103S-10-4	E113163-1	10	0.16	C14	-4	80
MF300-103S-15-4	E113164-1	15	0.16	C14	-4	80
MF300-103S-16-4	E113165-1	16	0.16	C20	-4	120
MF300-103S-20-4	E113166-1	20	0.16	C20	-4	120
MF300-503S-1-4	E113167-1	1	0.16	C14	-4	80
MF300-503S-2-4	E113168-1	2	0.16	C14	-4	80
MF300-503S-3-4	E113169-1	3	0.16	C14	-4	80
MF300-503S-6-4	E113170-1	6	0.16	C14	-4	80
MF300-503S-10-4	E113171-1	10	0.16	C14	-4	80
MF300-503S-15-4	E113172-1	15	0.16	C14	-4	80
MF300-503S-16-4	E113173-1	16	0.16	C20	-4	120
MF300-503S-20-4	E113174-1	20	0.16	C20	-4	120

Medical Version : Very High Performance						
Model Number	Part Number	Current Rating @40°C(A)	Leakage Current @250 VAC/50Hz (µA)	Input Connector	Output Termination 	Min.Weight (g)
MF300-103M-1-4	E113143-1	1	0	C14	-4	80
MF300-103M-2-4	E113144-1	2	0	C14	-4	80
MF300-103M-3-4	E113145-1	3	0	C14	-4	80
MF300-103M-6-4	E113146-1	6	0	C14	-4	80
MF300-103M-10-4	E113147-1	10	0	C14	-4	80
MF300-103M-15-4	E113148-1	15	0	C14	-4	80
MF300-103M-16-4	E113149-1	16	0	C20	-4	120
MF300-103M-20-4	E113150-1	20	0	C20	-4	120
MF300-503M-1-4	E113151-1	1	0	C14	-4	80
MF300-503M-2-4	E113152-1	2	0	C14	-4	80
MF300-503M-3-4	E113153-1	3	0	C14	-4	80
MF300-503M-6-4	E113154-1	6	0	C14	-4	80
MF300-503M-10-4	E113155-1	10	0	C14	-4	80
MF300-503M-15-4	E113156-1	15	0	C14	-4	80
MF300-503M-16-4	E113157-1	16	0	C20	-4	120
MF300-503M-20-4	E113158-1	20	0	C20	-4	120

Note :

The EMI filter model name for MF140 has been updated to MF300-XXXM-YY-ZZ.

Product Selector

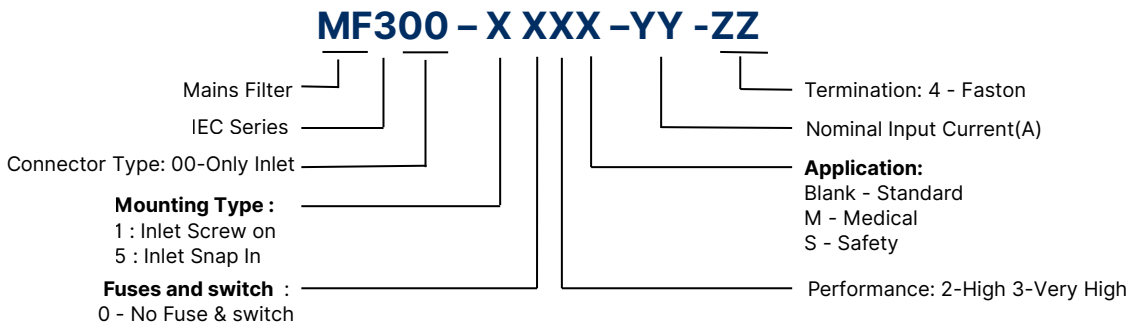

Insertion Loss : High Performance

..... Common mode _____ Differential Mode

Per CISPR 17 C=50Ω/50Ω D=50Ω/50Ω

Standard Version

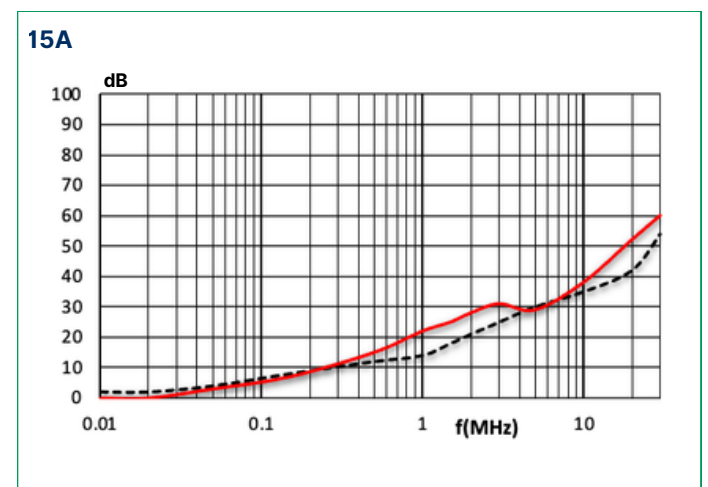
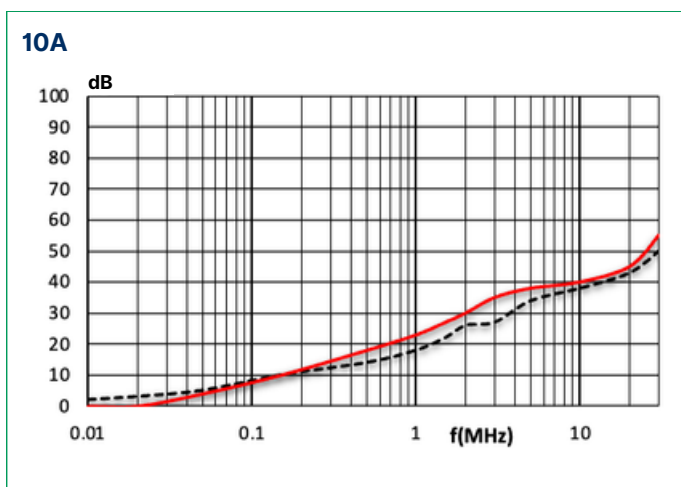
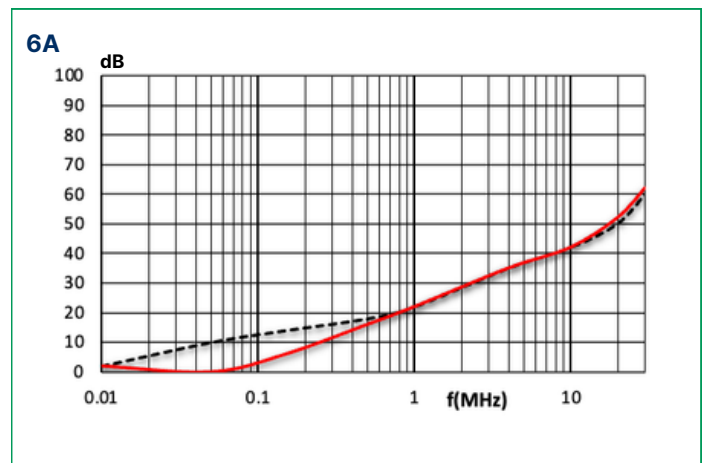
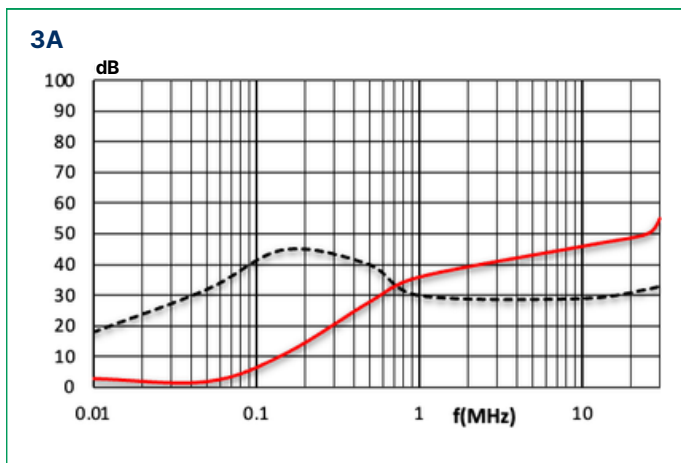
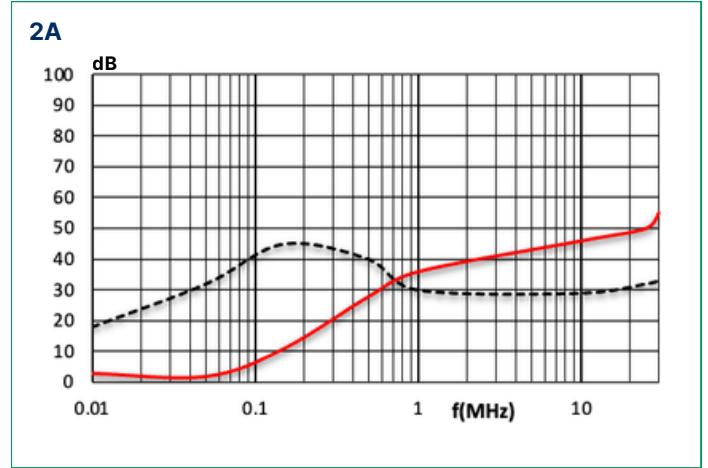
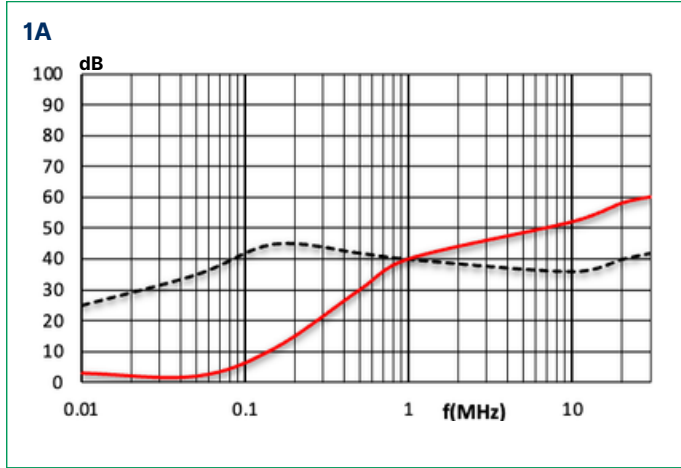

16A

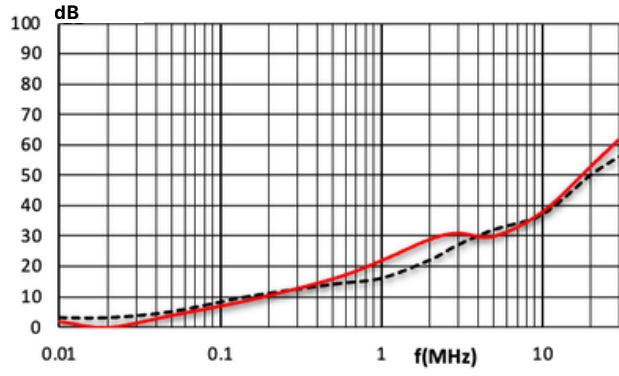

20A

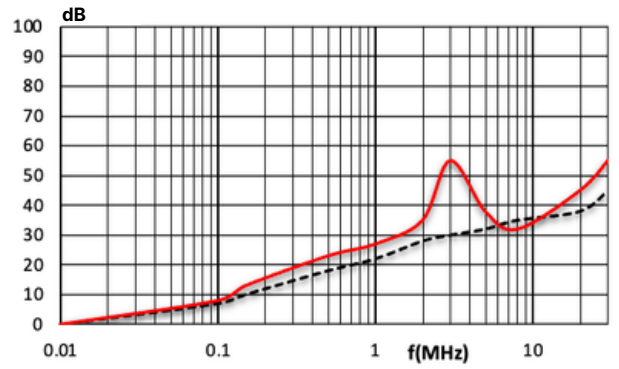

Safety Version

1A

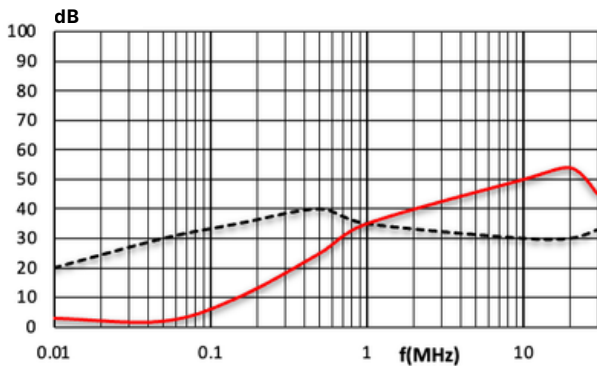

2A

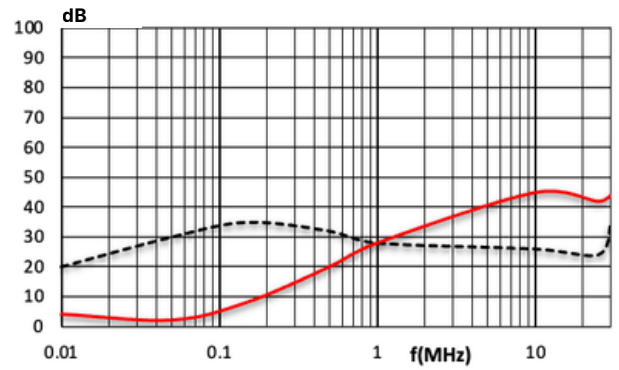

3A

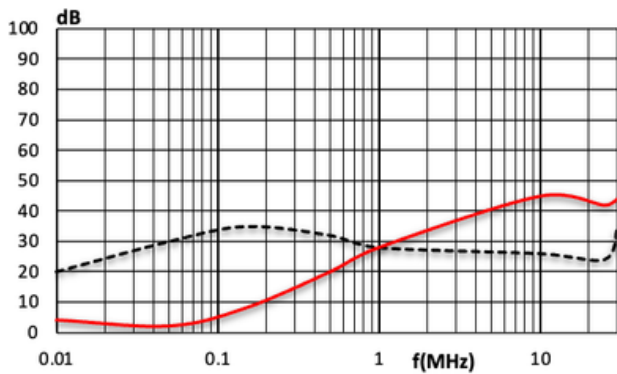

6A

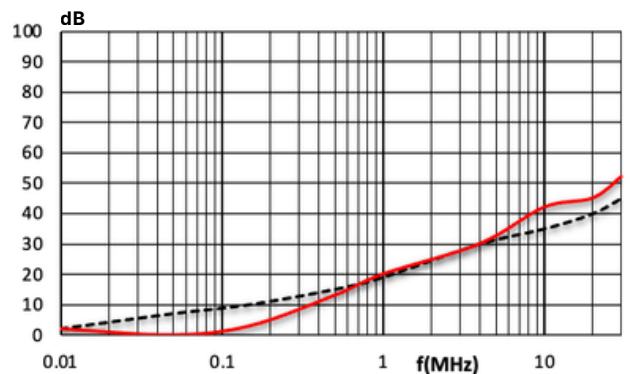

10A

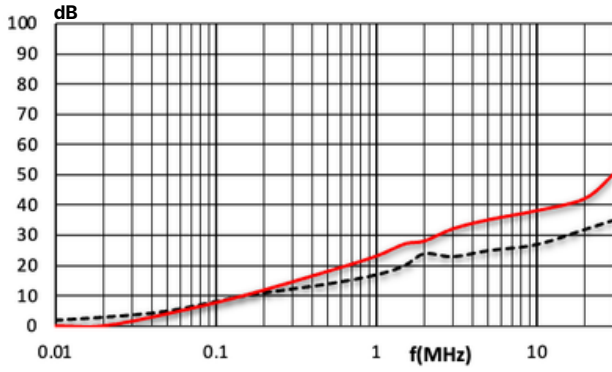

15A

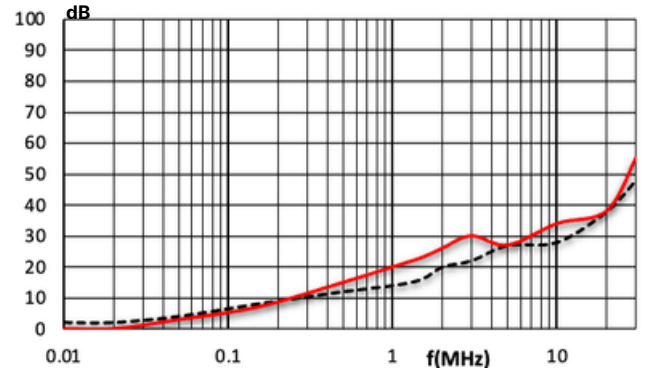

16A

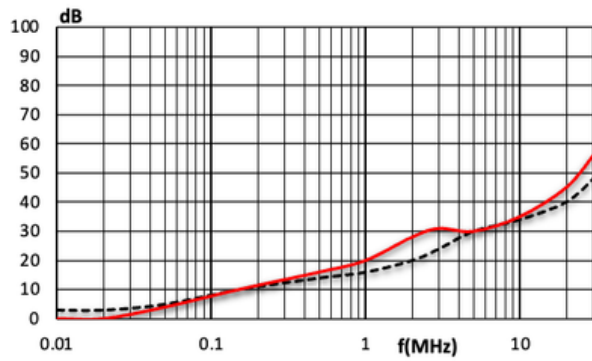

20A

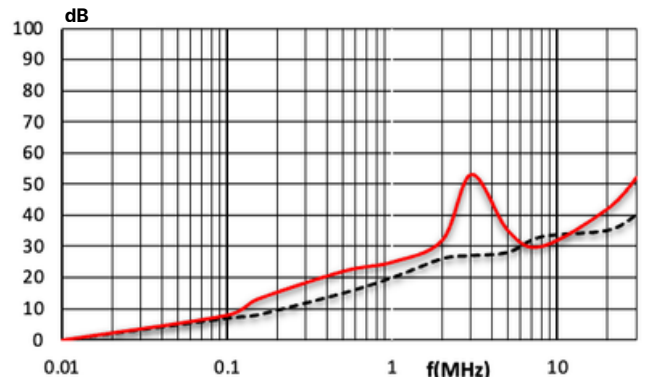

Medical Version

1A

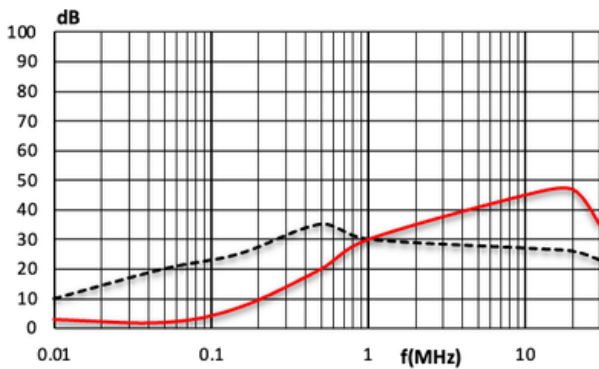

2A

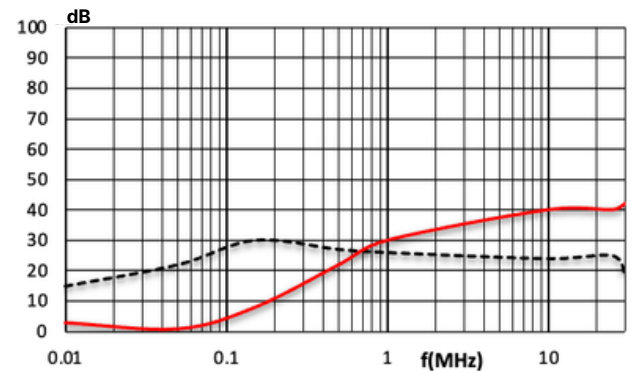

3A

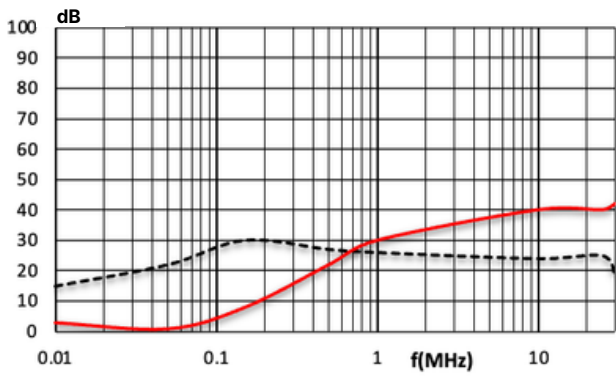

6A

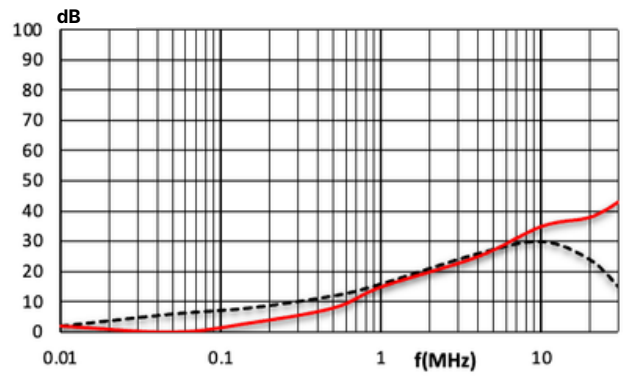

10A

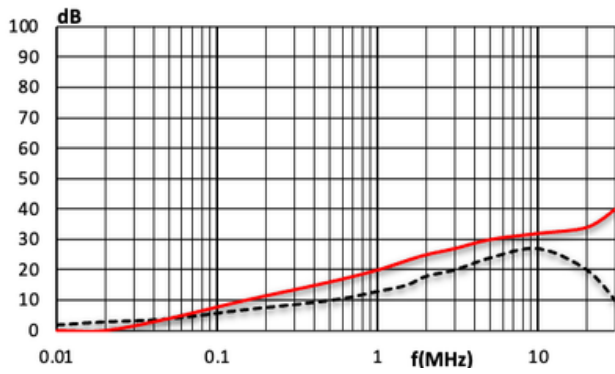

15A

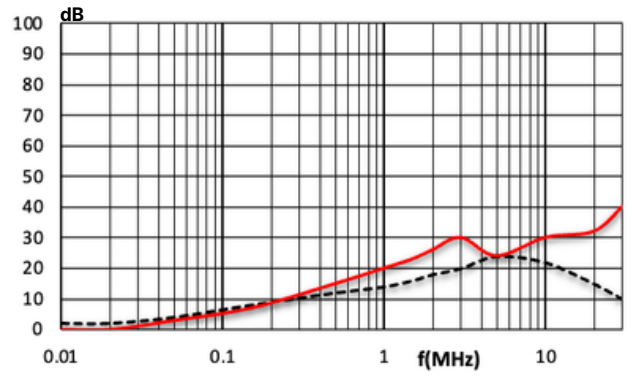

16A

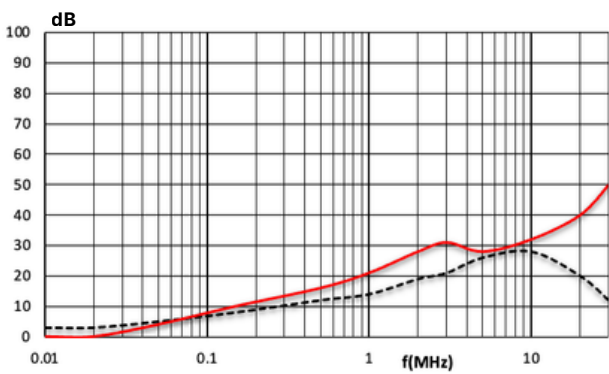

20A

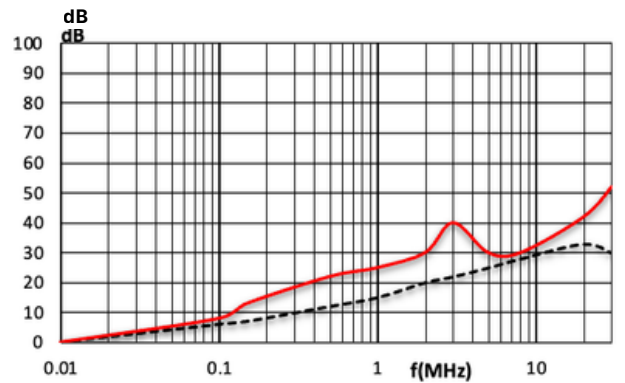

Insertion Loss : Very High Performance

Standard Version

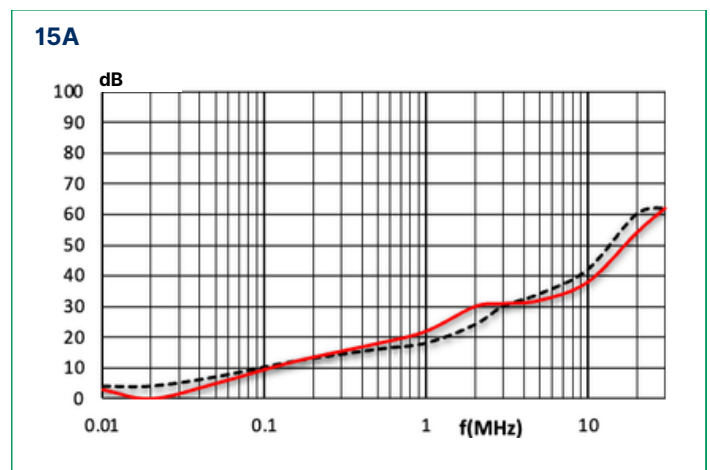
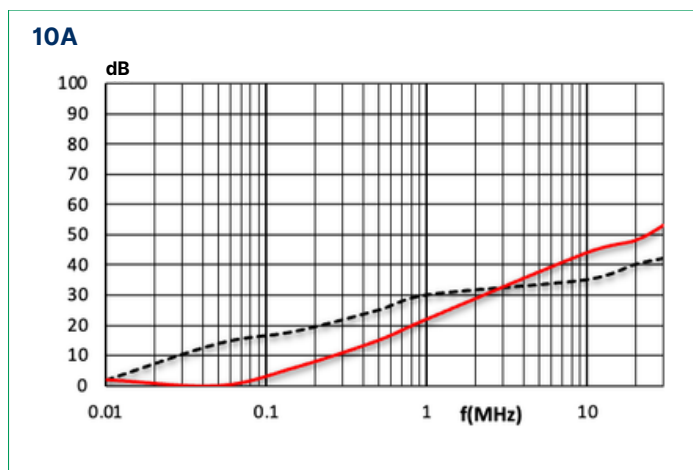
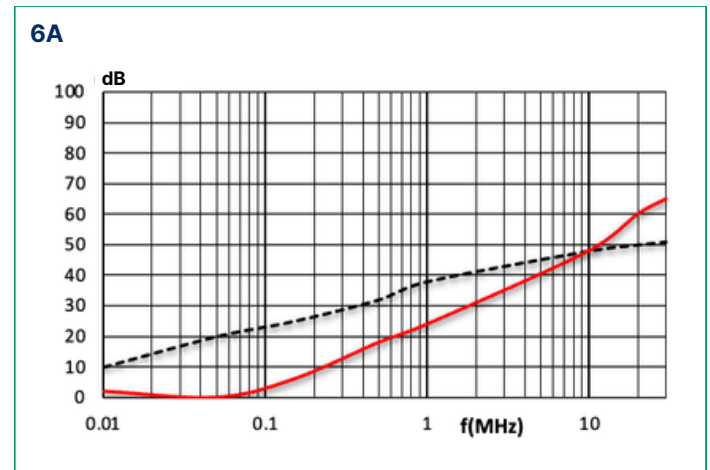
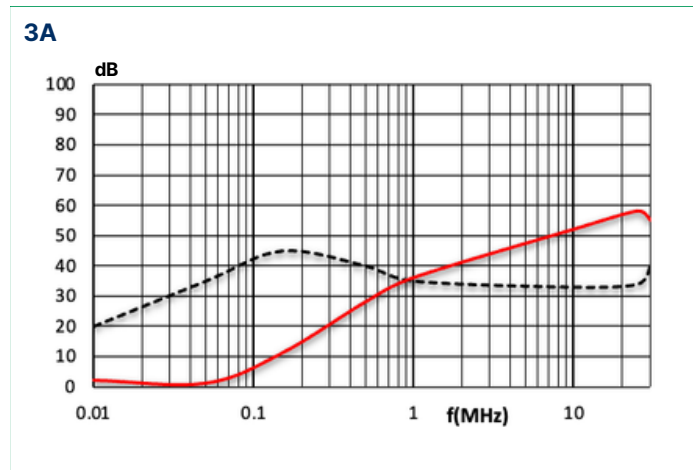
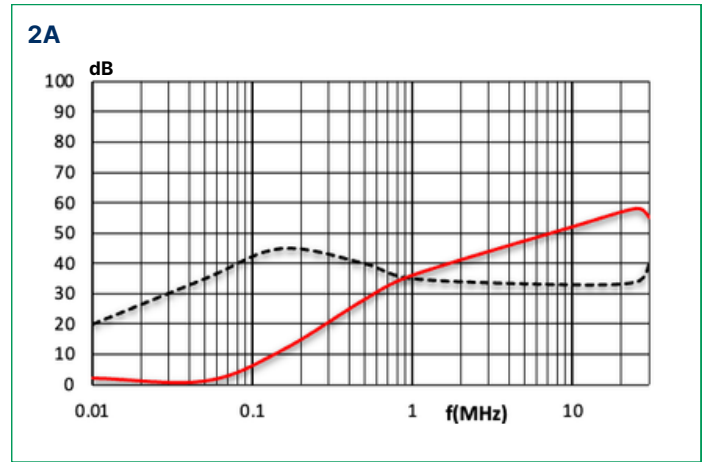
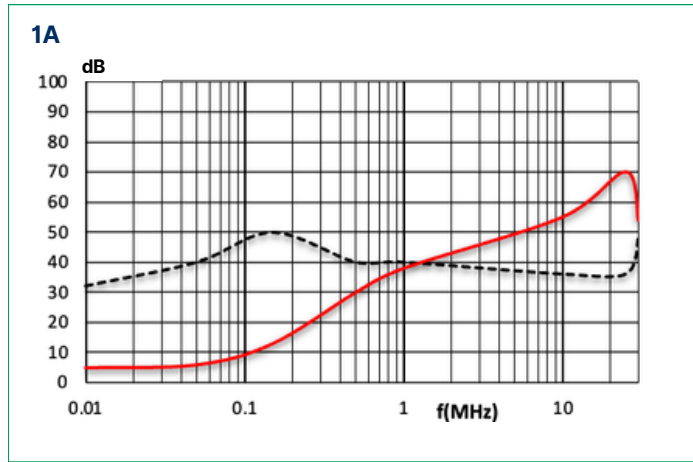

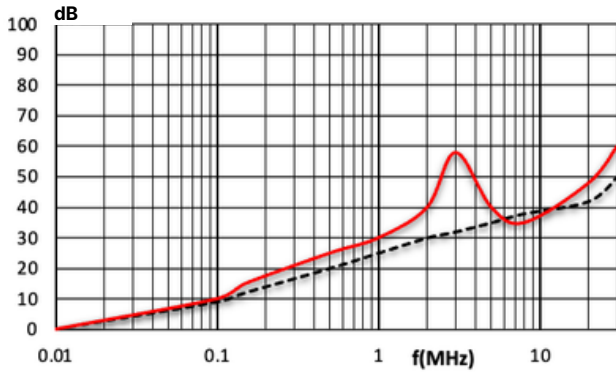
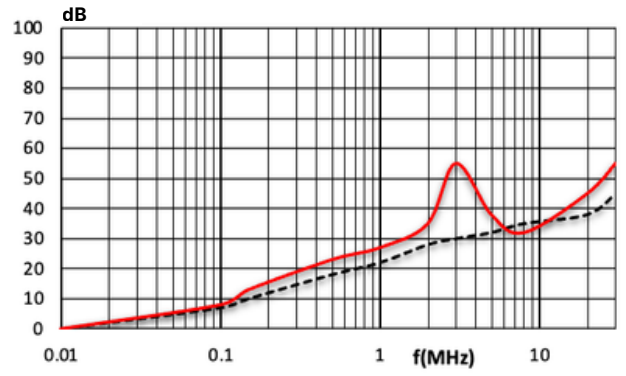
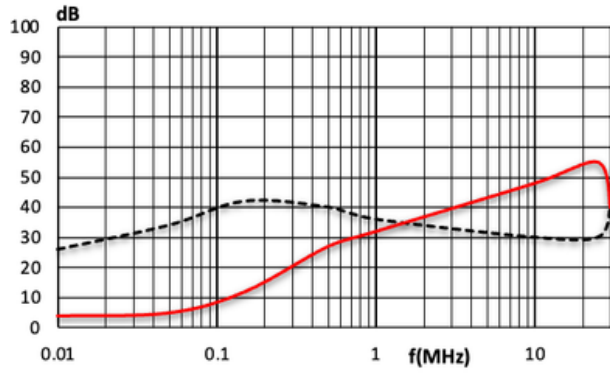
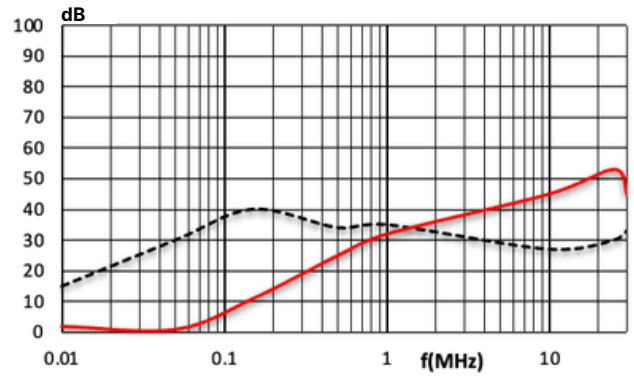
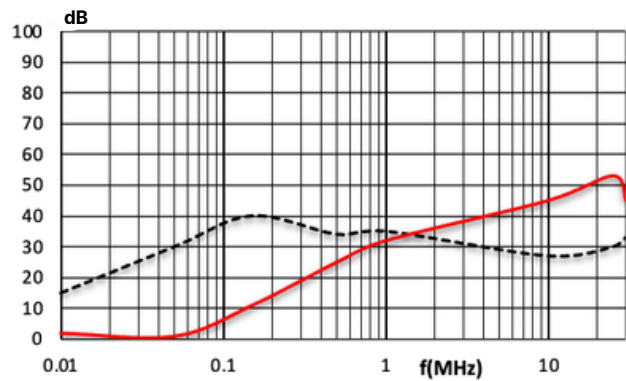
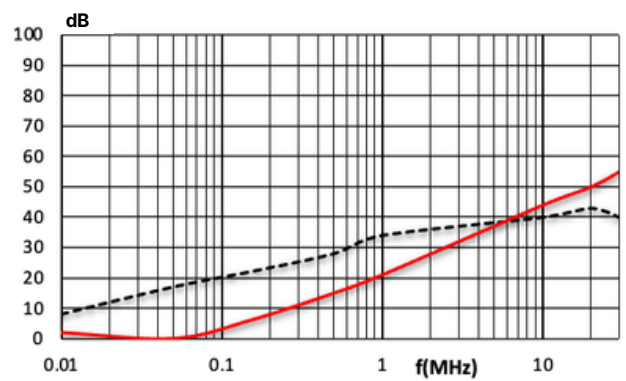
16A**20A****Safety Version****1A****2A****3A****6A**

10A

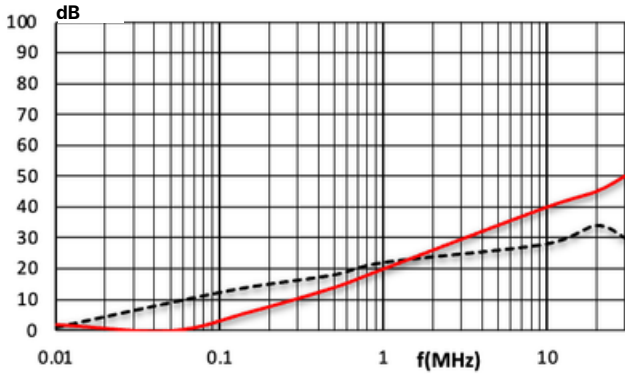

15A

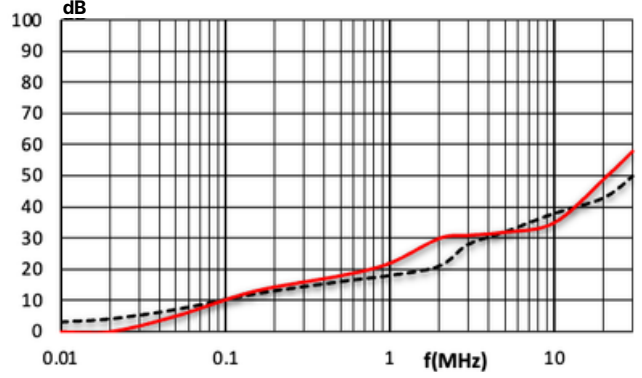

16A

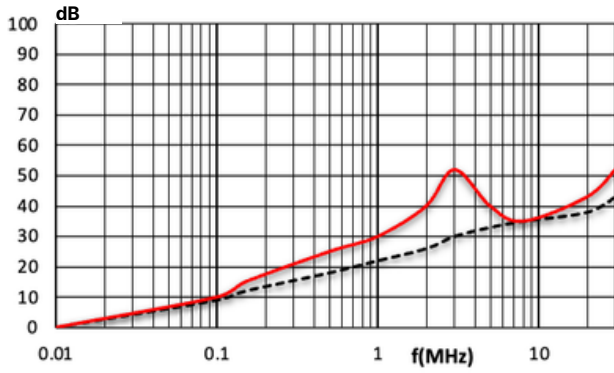

20A

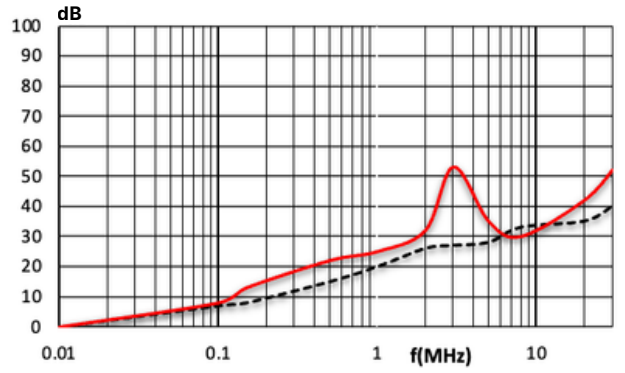

Medical Version

1A

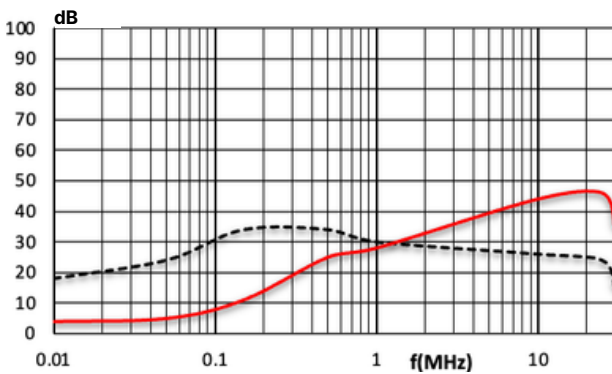

2A

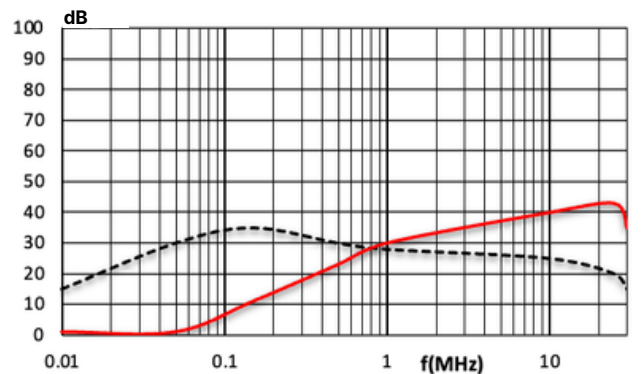

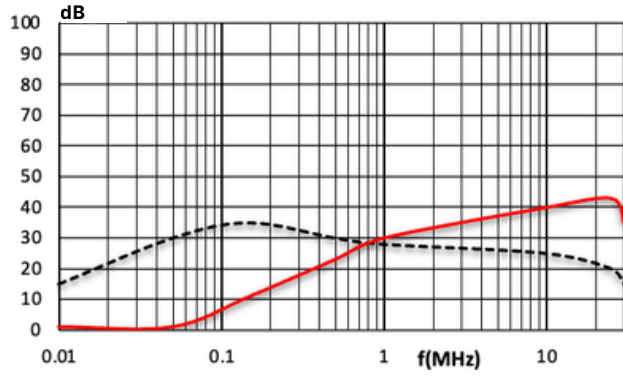
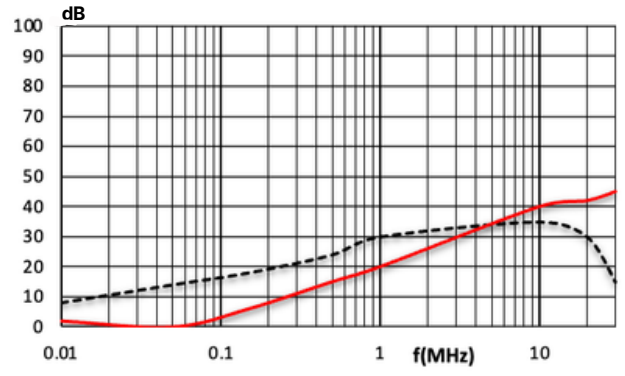
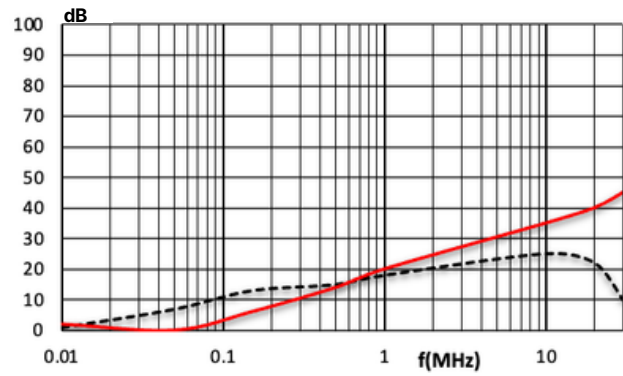
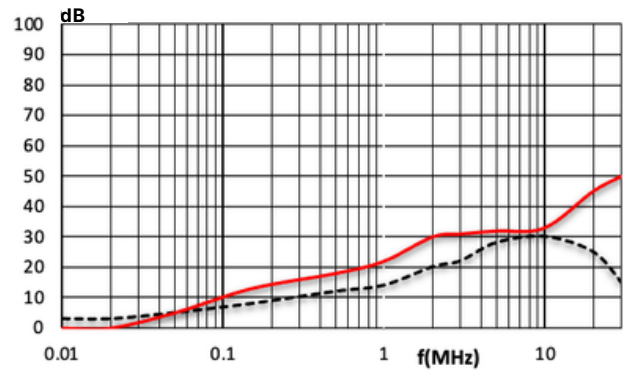
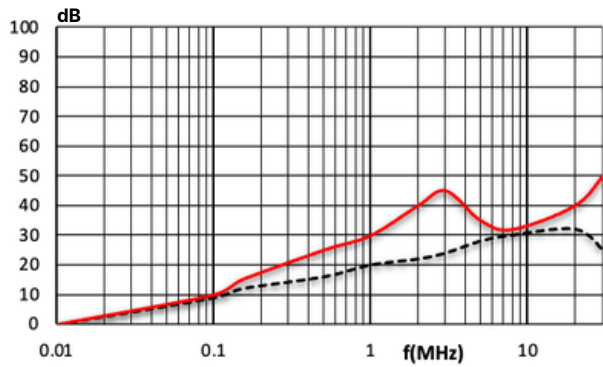
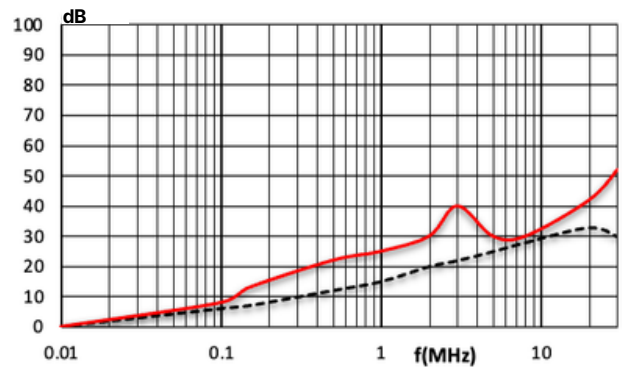
3A**6A****10A****15A****16A****20A**

Mechanical Drawing

Screw Mount 1A to 15A - C14 Connector

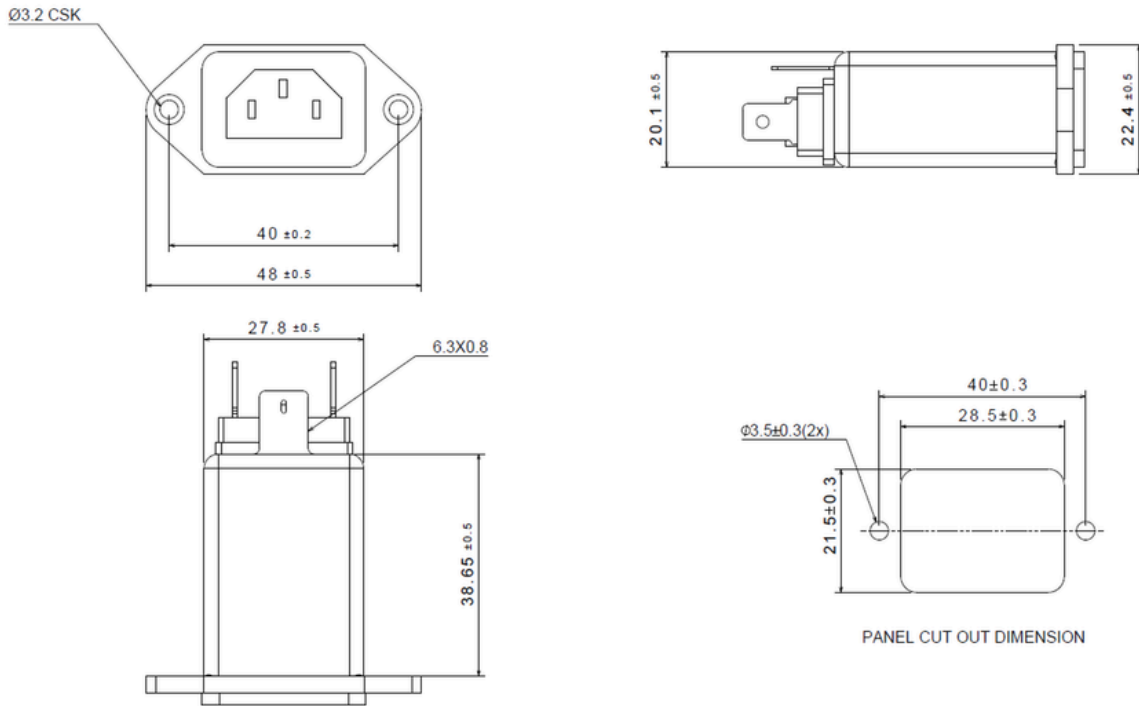

Screw Mount 16A & 20A - C20 Connector

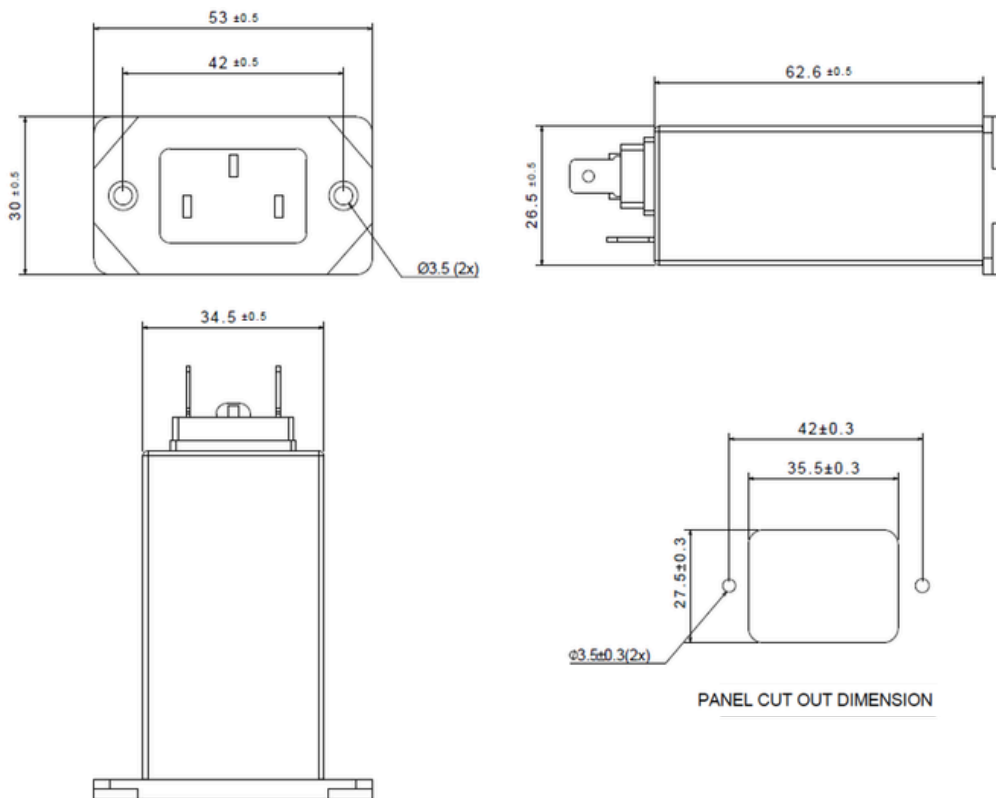

Snap in Mount 1A to 15A - C14 Connector

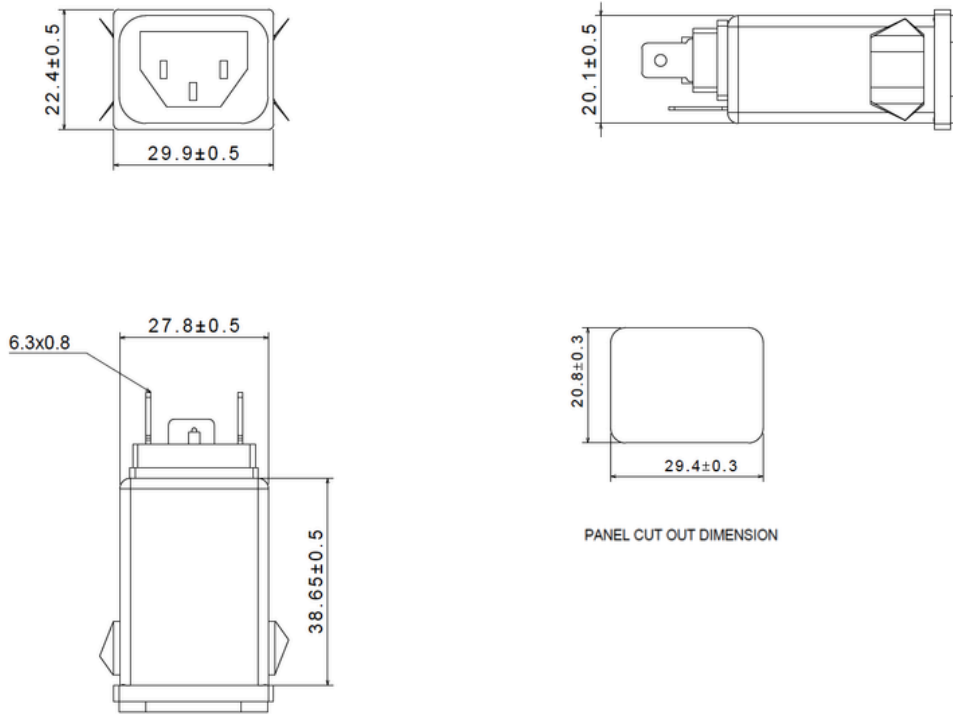

Snap in Mount 16A & 20A - C20 Connector

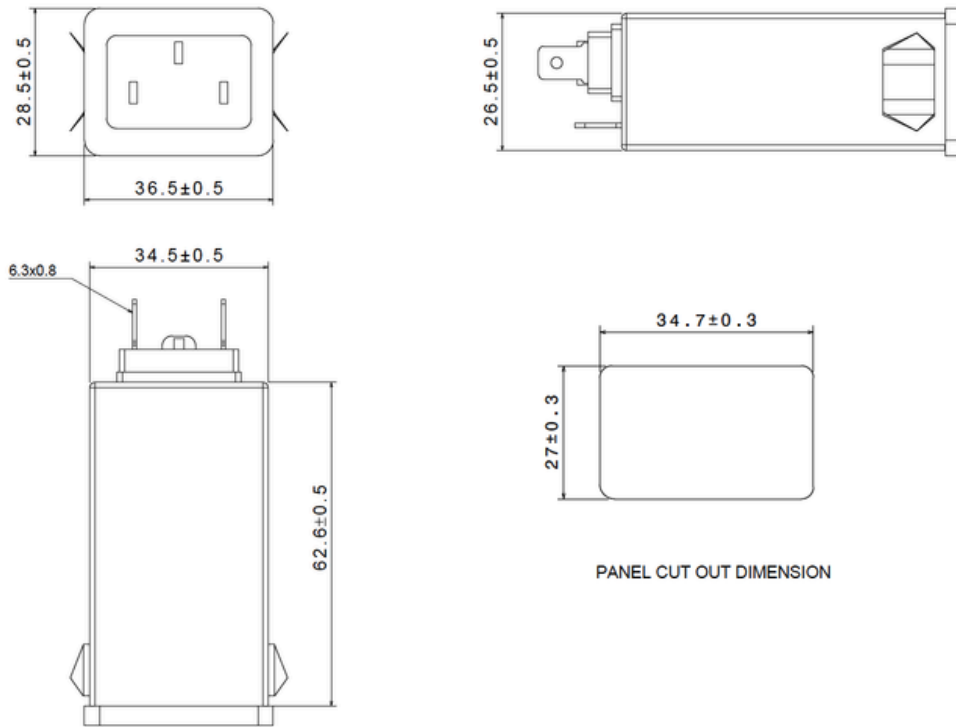

Note: All dimensions in mm, unless otherwise specified general tolerance applicable ISO2768-C.