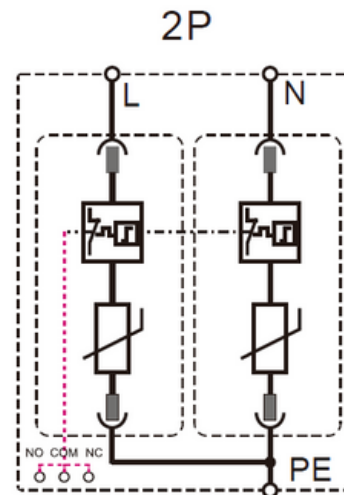

Features:

- Modular design, plug-in structure
- Easy maintenance and replacement
- Multi-window release indication
- With overheat and overcurrent disengagement device
- Thermal cut-off device, providing reliable protection
- Fast response time, high reliability and stable performance

Applications:

- Electric power supply networks
- Automatic control buses
- Electric Vehicle Charging Stations

Type Circuit Diagram:

DATASHEET

Single phase Surge Protector – SSP2406

A surge protector is a device designed to protect electrical systems from voltage spikes or surges in three-phase power systems. These surges can be caused by various factors, such as lightning strikes, power outages, or switching operations. The protector works by diverting excess voltage away from sensitive equipment and directing it to the ground.

Technical Specifications:

Part Number	:E112448-1
SPD type	:T2/Class C
Nominal Continuous Operating Voltage	:250VAC
Maximum Continuous Operating Voltage	:275VAC
Nominal discharge current 15x 8/20 μ s impulses	:20kA
Maximum discharge current 15x 8/20 μ s	:40kA
Response Time	: \leq 25ns
Connecting Conductor Cross Section	:2.5 to 25 mm ²
Operating temperature	: -40°C to $+80^{\circ}\text{C}$
Maximum Backup Fuse	:100 A CylgG

Temporary Over Voltage (TOV) Characteristics-5 sec. without disconnection	:1200V/5 sec
Temporary Over Voltage (TOV) Characteristics-120 min without disconnection	:440V/120 min Withstand
Residual Current Leakage current to Ground	:<20 μ A
Protection mode(s)	:L-PE
Protection level L/PE @ In (8/20 μ s)	: \leq 1.5 kV
Admissible short-circuit current	:25kA rms
Technology	:MOV
SPD configuration	:One port
Connection to Network By screw terminals	:Yes
Mounting	:35mm DIN Rail
Housing material	:Flame Retardant PBT
Protection rating	:IP 20
Failsafe mode	:Thermal Disconnect
Disconnection indicator	:Yes
Spare module(s)	:Available
Remote signaling of disconnection	:Yes
wiring for remote signaling	:COM,NC,NO
Max. Voltage/Current for remote signaling	:AC: 250V/1.0A
Weight(KG)	:0.4KG
Thermal disconnect	:YES
Back-up protection device	:Necessary
Test Standard	:IEC 61643-11
Accessories	:Cartridge:40kA :Part Number: E113088-1

Mechanical Information

