

Features:

- Current rating from 10A to 230A
- High EMI attenuation
- Compliance with Class C2 and C1 limits.
- Book-style with convenient size
- High Voltage upto 760VAC
- Various versions are available ,such as Standard, High Voltage and High Voltage with IT Networks

Applications:

- Variable speed drives and power drive systems (PDS).
- Machine tools and machinery equipment.
- IT power distribution networks.
- Inverters, converters
- Process automation equipment.
- Three-phase power supplies.

Performance Indicator:

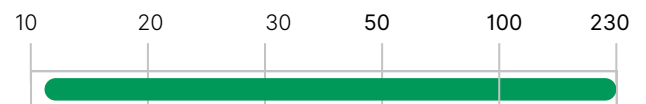
Rated Current (A):

DATASHEET
**THREE PHASE EMI FILTER-
TMF3221/TMF3222**

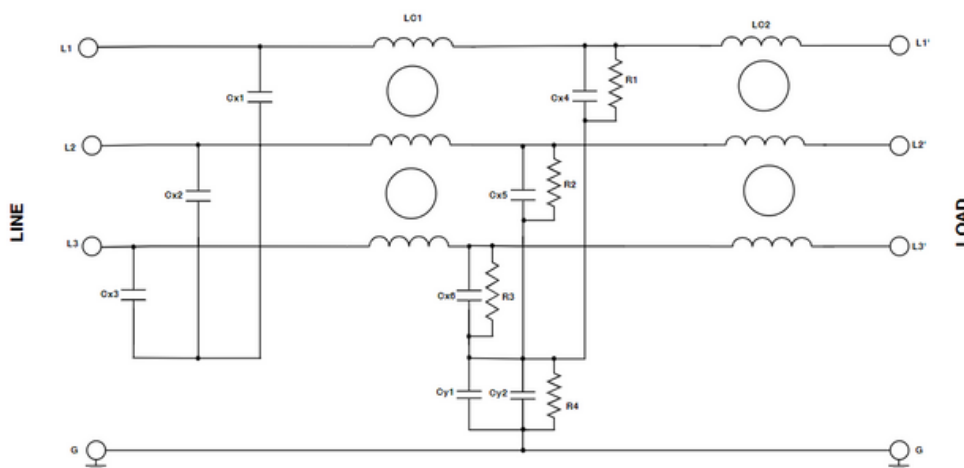
This series is mainly designed for variable speed motors and power drive systems, delivering reliable EMC performance for both standard and high-level applications. They reduce conducted noise, even under significant interference, meeting EN61800-3 Category C2 and C1 environmental requirements.

Type Circuit Diagram:

Note: R4 is not applicable for the IT Network application.

Technical Specifications:

Maximum Continuous Operating Voltage	:520VAC (TMF3221) (TMF3222) (TMF3222IT) 760VAC (TMF3222HV) (TMF3222HVIT)
Operating Frequency	:50/60 Hz
Current ratings	:10A to 230A @50°C
High Potential test voltage	:L -> G 2884 VDC for 2 s (TMF3221) (TMF3222) L -> L 2279 VDC for 2 s (TMF3221) (TMF3222) L-> G 3528 VDC for 2 s(TMF3222HV) L -> L 3268 VDC for 2 s(TMF3222HV)
Overload Capability	:4x rated current at switch on, 135% of rated current for 15Mins
Flammability according to	:UL 94 V-0
Protection category	:IP 20
Overvoltage category	:III acc. IEC 60664-1
Design Corresponding to	:UL 60939-3 & IEC 60939-1&2,CSA C22.2 No.8-13
Temperature range	:-40°C to +100°C
Climatic Category	:40/100/21
Compliance with insulation requirement	:> 1MΩ acc. to IEC 60204-1

Ordering Information

Standard Performance Version									
Model Number	Part Number	Current Rating @50°C(A)	Leakage Current @520 VAC/50Hz (mA)			Power loss @25°C / 50Hz (W)	Termination 	Min.Weight (kg)	Enclosure
			C3	C6	C9				
TMF3221-10-2-C3-RB1	E108365-1	10	0.4	-	-	7.5	-2 (06)	0.7	Q
TMF3221-10-2-C6-RB1	E108365-2	10	-	2.2	-	7.5	-2 (06)	0.7	Q
TMF3221-10-2-C9-RB1	E108365-3	10	-	-	4.2	7.5	-2 (06)	0.7	Q
TMF3221-16-2-C3-RB1	E108366-1	16	0.4	-	-	9.5	-2 (06)	0.8	R
TMF3221-16-2-C6-RB1	E108366-2	16	-	2.4	-	9.5	-2 (06)	0.8	R
TMF3221-16-2-C9-RB1	E108366-3	16	-	-	4.3	9.5	-2 (06)	0.8	R
TMF3221-20-2-C3-RB1	E108367-1	20	0.4	-	-	10	-2 (06)	0.9	S
TMF3221-20-2-C6- RB1	E108367-2	20	-	2.5	-	10	-2 (06)	0.9	S
TMF3221-20-2-C9-RB1	E108367-3	20	-	-	4.9	10	-2 (06)	0.9	S
TMF3221-25-2-C3-RB1	E108369-1	25	0.4	-	-	11.5	-2 (06)	1	S
TMF3221-25-2-C6-RB1	E108369-2	25	-	2.5	-	11.5	-2 (06)	1	S
TMF3221-25-2-C9-RB1	E108369-3	25	-	-	4.9	11.5	-2 (06)	1	S
TMF3221-40-2-C3-RB1	E108370-1	40	0.4	-	-	23	-2 (06)	1.5	T
TMF3221-40-2-C6-RB1	E108370-2	40	-	2.5	-	23	-2 (06)	1.5	T
TMF3221-40-2-C9-RB1	E108370-3	40	-	-	4.9	23	-2 (06)	1.5	T
TMF3221-50-2-C3-RB1	E108371-1	50	0.4	-	-	25.5	-2 (16)	2.1	U
TMF3221-50-2-C6-RB1	E108371-2	50	-	2.5	-	25.5	-2 (16)	2.1	U
TMF3221-50-2-C9-RB1	E108371-3	50	-	-	4.9	25.5	-2 (16)	2.1	U
TMF3221-63-2-C3-RB1	E108372-1	63	0.4	-	-	32.5	-2 (16)	2.2	U
TMF3221-63-2-C6-RB1	E108372-2	63	-	2.5	-	32.5	-2 (16)	2.2	U
TMF3221-63-2-C9-RB1	E108372-3	63	-	-	4.9	32.5	-2 (16)	2.2	U
TMF3221-80-2-C3-RB1	E108373-1	80	0.4	-	-	33	-2 (35)	3.4	F
TMF3221-80-2-C6-RB1	E108373-2	80	-	2.7	-	33	-2 (35)	3.4	F
TMF3221-80-2-C9-RB1	E108373-3	80	-	-	5.6	33	-2 (35)	3.4	F
TMF3221-100-2-C3-RB1	E108374-1	100	0.4	-	-	33.5	-2 (50)	4.2	G
TMF3221-100-2-C6-RB1	E108374-2	100	-	2.7	-	33.5	-2 (50)	4.2	G
TMF3221-100-2-C9-RB1	E108374-3	100	-	-	5.6	33.5	-2 (50)	4.2	G
TMF3221-125-2-C3-RB1	E108375-1	125	0.4	-	-	37.5	-2 (50)	4.6	G
TMF3221-125-2-C6-RB1	E108375-2	125	-	2.7	-	37.5	-2 (50)	4.6	G
TMF3221-125-2-C9-RB1	E108375-3	125	-	-	5.6	37.5	-2 (50)	4.6	G
TMF3221-160-2-C3-RB1	E108376-1	160	0.4	-	-	38.5	-2 (95)	6	H
TMF3221-160-2-C6-RB1	E108376-2	160	-	2.7	-	38.5	-2 (95)	6	H
TMF3221-160-2-C9-RB1	E108376-3	160	-	-	5.6	38.5	-2 (95)	6	H
TMF3221-230-2-C3-RB1	E108377-1	230	0.4	-	-	48	-2 (95)	8.8	V
TMF3221-230-2-C6-RB1	E108377-2	230	-	2.7	-	48	-2 (95)	8.8	V
TMF3221-230-2-C9-RB1	E108377-3	230	-	-	5.9	48	-2 (95)	8.8	V

High Performance Version

Model Number	Number	Current Rating @50°C (A)	Leakage Current @520 VAC/50Hz (mA)				Power loss @25°C / 50Hz (W)	Termination 	Min.Weight (kg)	Enclosure
			C2	C3	C6	C11				
TMF3222-10-2-C2-RB1	E108378-1	10	0.1	-	-	-	7.5	-2 (06)	0.8	A
TMF3222-10-2-C3-RB1	E108378-2	10	-	0.4	-	-	7.5	-2 (06)	0.8	A
TMF3222-10-2-C6-RB1	E108378-3	10	-	-	2.5	-	7.5	-2 (06)	0.8	A
TMF3222-10-2-C11-RB1	E108378-4	10	-	-	-	6	7.5	-2 (06)	0.8	A
TMF3222-16-2-C2-RB1	E108379-1	16	0.1	-	-	-	10.5	-2 (06)	1	B
TMF3222-16-2-C3-RB1	E108379-2	16	-	0.4	-	-	10.5	-2 (06)	1	B
TMF3222-16-2-C6-RB1	E108379-3	16	-	-	2.5	-	10.5	-2 (06)	1	B
TMF3222-16-2-C11-RB1	E108379-4	16	-	-	-	6	10.5	-2 (06)	1	B
TMF3222-20-2-C2-RB1	E108380-1	20	0.1	-	-	-	11	-2 (06)	1.2	C
TMF3222-20-2-C3-RB1	E108380-2	20	-	0.4	-	-	11	-2 (06)	1.2	C
TMF3222-20-2-C6-RB1	E108380-3	20	-	-	2.5	-	11	-2 (06)	1.2	C
TMF3222-20-2-C11-RB1	E108380-4	20	-	-	-	6	11	-2 (06)	1.2	C
TMF3222-25-2-C2-RB1	E108381-1	25	0.1	-	-	-	18	-2 (06)	1.2	C
TMF3222-25-2-C3-RB1	E108381-2	25	-	0.4	-	-	18	-2 (06)	1.2	C
TMF3222-25-2-C6-RB1	E108381-3	25	-	-	2.5	-	18	-2 (06)	1.2	C
TMF3222-25-2-C11-RB1	E108381-4	25	-	-	-	6	18	-2 (06)	1.2	C
TMF3222-40-2-C2-RB1	E108382-1	40	0.1	-	-	-	22	-2 (06)	1.8	D
TMF3222-40-2-C3-RB1	E108382-2	40	-	0.4	-	-	22	-2 (06)	1.8	D
TMF3222-40-2-C6-RB1	E108382-3	40	-	-	3.5	-	22	-2 (06)	1.8	D
TMF3222-40-2-C11-RB1	E108382-4	40	-	-	-	6	22	-2 (06)	1.8	D
TMF3222-50-2-C2-RB1	E108383-1	50	0.1	-	-	-	30	-2 (16)	2.5	E
TMF3222-50-2-C3-RB1	E108383-2	50	-	0.4	-	-	30	-2 (16)	2.5	E
TMF3222-50-2-C6-RB1	E108383-3	50	-	-	2.6	-	30	-2 (16)	2.5	E
TMF3222-50-2-C11-RB1	E108383-4	50	-	-	-	6.6	30	-2 (16)	2.5	E
TMF3222-63-2-C2-RB1	E108384-1	63	0.1	-	-	-	35	-2 (16)	2.7	E
TMF3222-63-2-C3-RB1	E108384-2	63	-	0.4	-	-	35	-2 (16)	2.7	E
TMF3222-63-2-C6-RB1	E108384-3	63	-	-	2.6	-	35	-2 (16)	2.7	E
TMF3222-63-2-C11-RB1	E108384-4	63	-	-	-	6.6	35	-2 (16)	2.7	E
TMF3222-80-2-C2-RB1	E108385-1	80	0.1	-	-	-	29	-2 (35)	4.3	F
TMF3222-80-2-C3-RB1	E108385-2	80	-	0.4	-	-	29	-2 (35)	4.3	F
TMF3222-80-2-C6-RB1	E108385-3	80	-	-	2.7	-	29	-2 (35)	4.3	F
TMF3222-80-2-C11-RB1	E108385-4	80	-	-	-	7.1	29	-2 (35)	4.3	F
TMF3222-100-2-C2-RB1	E108386-1	100	0.1	-	-	-	36	-2 (50)	5.1	G
TMF3222-100-2-C3-RB1	E108386-2	100	-	0.4	-	-	36	-2 (50)	5.1	G
TMF3222-100-2-C6-RB1	E108386-3	100	-	-	2.7	-	36	-2 (50)	5.1	G
TMF3222-100-2-C11-RB1	E108386-4	100	-	-	-	7.1	36	-2 (50)	5.1	G
TMF3222-125-2-C2-RB1	E108387-1	125	0.1	-	-	-	42.5	-2 (50)	5	G
TMF3222-125-2-C3-RB1	E108387-2	125	-	0.4	-	-	42.5	-2 (50)	5	G
TMF3222-125-2-C6-RB1	E108387-3	125	-	-	2.7	-	42.5	-2 (50)	5	G
TMF3222-125-2-C11-RB1	E108387-4	125	-	-	-	7.1	42.5	-2 (50)	5	G
TMF3222-160-2-C2-RB1	E108388-1	160	0.1	-	-	-	46.5	-2 (95)	6.6	H
TMF3222-160-2-C3-RB1	E108388-2	160	-	0.4	-	-	46.5	-2 (95)	6.6	H
TMF3222-160-2-C6-RB1	E108388-3	160	-	-	2.7	-	46.5	-2 (95)	6.6	H
TMF3222-160-2-C11-RB1	E108388-4	160	-	-	-	7.1	46.5	-2 (95)	6.6	H
TMF3222-230-2-C2-RB1	E108389-1	230	0.1	-	-	-	48	-2 (95)	9.3	V
TMF3222-230-2-C3-RB1	E108389-2	230	-	0.4	-	-	48	-2 (95)	9.3	V
TMF3222-230-2-C6-RB1	E108389-3	230	-	-	2.7	-	48	-2 (95)	9.3	V
TMF3222-230-2-C11-RB1	E108389-4	230	-	-	-	7.1	48	-2 (95)	9.3	V

High Performance for IT Power Networks

Model Number	Part Number	Current Rating @50°C (A)	Leakage Current @520 VAC/50Hz (mA)		Power loss @25°C / 50Hz (W)	Termination 	Min.Weight (kg)	Enclosure
			C10					
TMF3222IT-10-2-C10-RB1	E108390-1	10	5.9		6.5	-2 (06)	1.1	I
TMF3222IT-16-2-C10-RB1	E108391-1	16	5.9		10	-2 (06)	1.3	J
TMF3222IT-20-2-C10-RB1	E108392-1	20	5.9		13.5	-2 (06)	1.6	K
TMF3222IT-25-2-C10-RB1	E108393-1	25	5.9		16	-2 (06)	1.6	K
TMF3222IT-40-2-C10-RB1	E108394-1	40	5.9		19	-2 (06)	2.8	L
TMF3222IT-50-2-C10-RB1	E108395-1	50	6.5		24	-2 (16)	2.8	M
TMF3222IT-63-2-C10-RB1	E108396-1	63	6.5		30	-2 (16)	2.9	M
TMF3222IT-80-2-C10-RB1	E108397-1	80	7		30	-2 (35)	4.6	N
TMF3222IT-100-2-C10-RB1	E108398-1	100	7		33	-2 (50)	5.4	O
TMF3222IT-125-2-C10-RB1	E108399-1	125	7		42.5	-2 (50)	5.3	O
TMF3222IT-160-2-C10-RB1	E108400-1	160	7		46.5	-2 (95)	6.9	P
TMF3222IT-230-2-C10-RB1	E108401-1	230	7		48	-2 (95)	9.3	V

High Voltage Version

Model Number	Part Number	Current Rating @50°C (A)	Leakage Current @520 VAC/50Hz (mA)		Power loss @25°C / 50Hz (W)	Termination 	Min.Weight (kg)	Enclosure
			C5	C12				
TMF3222HV-10-2-C5-RB1	E108402-1	10	2.2	-	7	-2 (06)	1.2	I
TMF3222HV-10-2-C12-RB1	E108402-2	10	-	8.4	7	-2 (06)	1.2	I
TMF3222HV-16-2-C5-RB1	E108403-1	16	2.5	-	11	-2 (06)	1.5	J
TMF3222HV-16-2-C12-RB1	E108403-2	16	-	9.2	11	-2 (06)	1.5	J
TMF3222HV-20-2-C5-RB1	E108404-1	20	2.5	-	13	-2 (06)	1.8	K
TMF3222HV-20-2-C12-RB1	E108404-2	20	-	10.9	13	-2 (06)	1.8	K
TMF3222HV-25-2-C5-RB1	E108405-1	25	2.5	-	15	-2 (06)	1.9	K
TMF3222HV-25-2-C12-RB1	E108405-2	25	-	10.9	15	-2 (06)	1.9	K
TMF3222HV-40-2-C5-RB1	E108406-1	40	2.6	-	20	-2 (06)	2.9	L
TMF3222HV-40-2-C12-RB1	E108406-2	40	-	12.4	20	-2 (06)	2.9	L
TMF3222HV-50-2-C5-RB1	E108407-1	50	2.6	-	26.5	-2 (16)	3.3	M
TMF3222HV-50-2-C12-RB1	E108407-2	50	-	12.4	26.5	-2 (16)	3.3	M
TMF3222HV-63-2-C5-RB1	E108408-1	63	2.6	-	33.5	-2 (16)	3.5	M
TMF3222HV-63-2-C12-RB1	E108408-2	63	-	12.4	33.5	-2 (16)	3.5	M
TMF3222HV-80-2-C5-RB1	E108409-1	80	2.6	-	29	-2 (35)	4.9	N
TMF3222HV-80-2-C12-RB1	E108409-2	80	-	12.4	29	-2 (35)	4.9	N
TMF3222HV-100-2-C5-RB1	E108411-1	100	2.6	-	33	-2 (50)	5.8	O
TMF3222HV-100-2-C12-RB1	E108411-2	100	-	12.4	33	-2 (50)	5.8	O
TMF3222HV-125-2-C5-RB1	E108412-1	125	2.6	-	42	-2 (50)	5.9	O
TMF3222HV-125-2-C12-RB2	E108412-2	125	-	12.4	42	-2 (50)	5.9	O
TMF3222HV-160-2-C5-RB1	E108413-1	160	2.6	-	46.5	-2 (95)	7.2	P
TMF3222HV-160-2-C12-RB3	E108413-2	160	-	12.4	46.5	-2 (95)	7.2	P
TMF3222HV-230-2-C5-RB1	E108414-1	230	2.6	-	48	-2 (95)	9.3	V
TMF3222HV-230-2-C12-RB1	E108414-2	230	-	12.4	48	-2 (95)	9.3	V

High Voltage Version for IT Power Networks

Model Number	Part Number	Current Rating @50°C (A)	Leakage Current @520 VAC/50Hz (mA)		Power loss @25°C / 50Hz (W)	Termination 	Min. Weight (kg)	Enclosure
			C6	C14				
TMF3222HVIT-10-2-C6-RB1	E108415-1	10	3.6	-	7	-2 (06)	1.2	I
TMF3222HVIT-10-2-C14-RB1	E108415-2	10	-	4.6	7	-2 (06)	1.2	I
TMF3222HVIT-16-2-C6-RB1	E108416-1	16	3.7	-	11	-2 (06)	1.5	J
TMF3222HVIT-16-2-C14-RB1	E108416-2	16	-	6.8	11	-2 (06)	1.5	J
TMF3222HVIT-20-2-C6-RB1	E108417-1	20	3.7	-	13	-2 (06)	1.8	K
TMF3222HVIT-20-2-C14-RB1	E108417-2	20	-	6.8	13	-2 (06)	1.8	K
TMF3222HVIT-25-2-C6-RB1	E108418-1	25	3.7	-	15	-2 (06)	1.9	K
TMF3222HVIT-25-2-C14-RB1	E108418-2	25	-	6.8	15	-2 (06)	1.9	K
TMF3222HVIT-40-2-C6-RB1	E108419-1	40	3.7	-	19.5	-2 (06)	2.9	L
TMF3222HVIT-40-2-C14-RB1	E108419-2	40	-	6.8	19.5	-2 (06)	2.9	L
TMF3222HVIT-50-2-C6-RB1	E108420-1	50	3.7	-	26.5	-2 (16)	3.3	M
TMF3222HVIT-50-2-C14-RB1	E108420-2	50	-	6.8	26.5	-2 (16)	3.3	M
TMF3222HVIT-63-2-C6-RB1	E108421-1	63	3.7	-	33.5	-2 (16)	3.5	M
TMF3222HVIT-63-2-C14-RB1	E108421-2	63	-	6.8	33.5	-2 (16)	3.5	M
TMF3222HVIT-80-2-C6-RB1	E108422-1	80	3.7	-	29	-2 (35)	4.9	N
TMF3222HVIT-80-2-C14-RB1	E108422-2	80	-	6.8	29	-2 (35)	4.9	N
TMF3222HVIT-100-2-C6-RB1	E108423-1	100	3.7	-	33	-2 (50)	5.8	O
TMF3222HVIT-100-2-C14-RB1	E108423-2	100	-	6.8	33	-2 (50)	5.8	O
TMF3222HVIT-125-2-C6-RB1	E108424-1	125	3.7	-	42.5	-2 (50)	5.9	O
TMF3222HVIT-125-2-C14-RB1	E108424-2	125	-	6.8	42.5	-2 (50)	5.9	O
TMF3222HVIT-160-2-C6-RB1	E108425-1	160	3.7	-	46.5	-2 (95)	7.2	P
TMF3222HVIT-160-2-C14-RB1	E108425-2	160	-	6.8	46.5	-2 (95)	7.2	P
TMF3222HVIT-230-2-C6-RB1	E108426-1	230	3.7	-	47.5	-2 (95)	9.3	V
TMF3222HVIT-230-2-C14-RB1	E108426-2	230	-	12.4	47.5	-2 (95)	9.3	V

Note : Standardized Leakage Current calculation as per IEC60939 under normal operating conditions.

Insertion Loss:

----- Common mode ----- Differential Mode

Per CISPR 17; C=50 Ω/50 Ω D=50 Ω/50 Ω

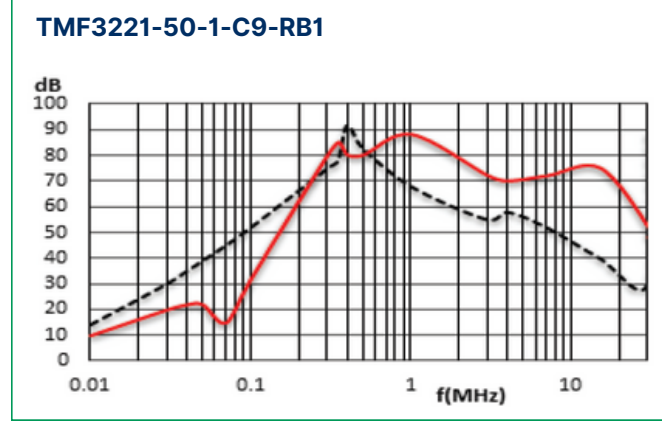
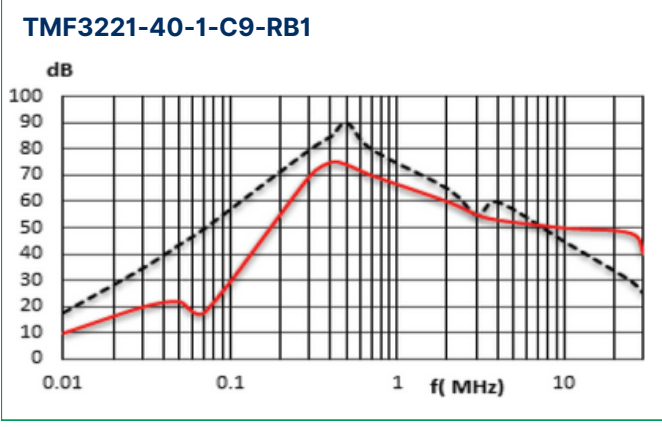
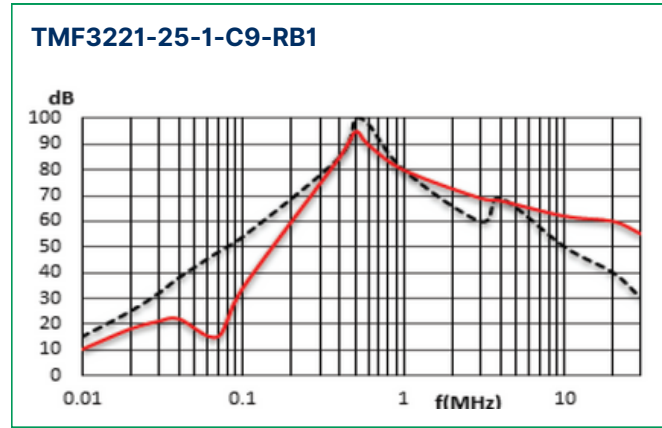
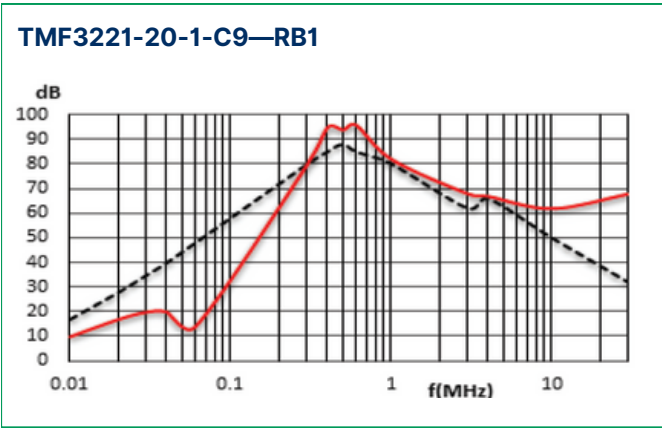
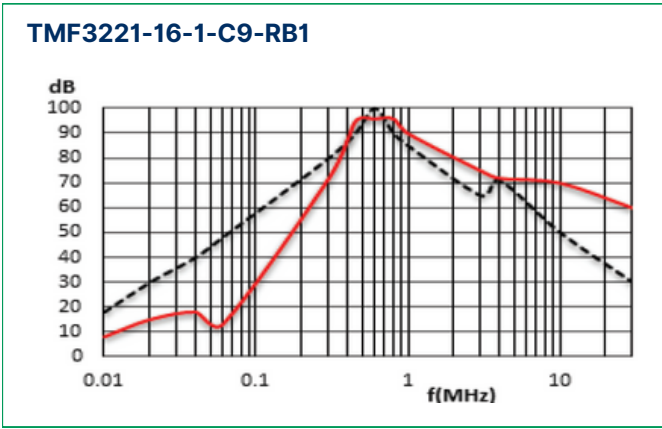
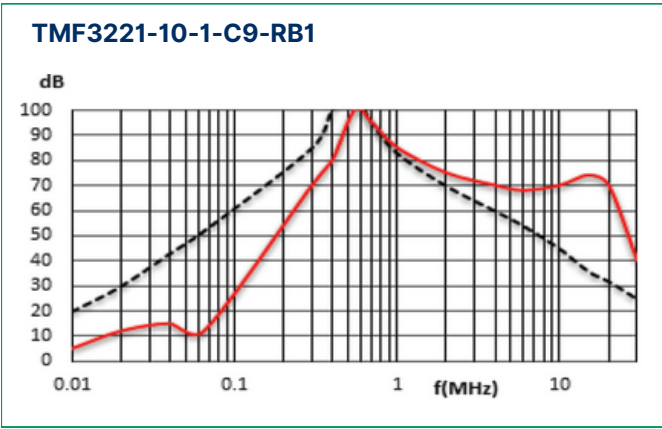

TMF3221-63-1-C9-RB1

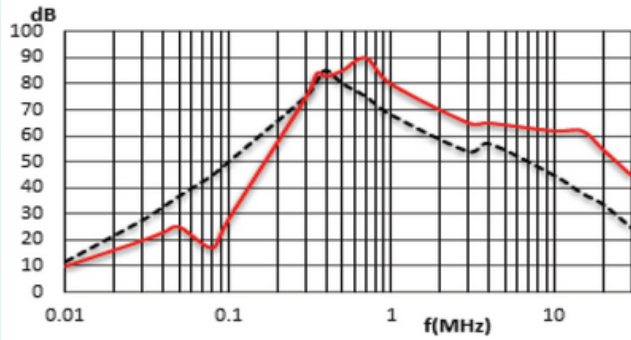

TMF3221-80-1-C9-RB1

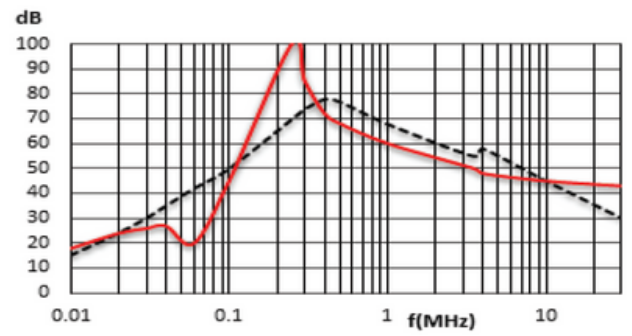

TMF3221-100-1-C9-RB1

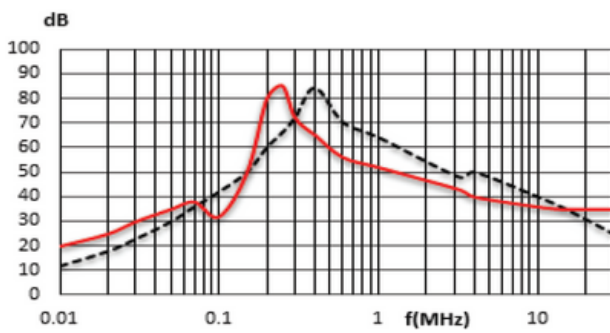

TMF3221-125-1-C9-RB1

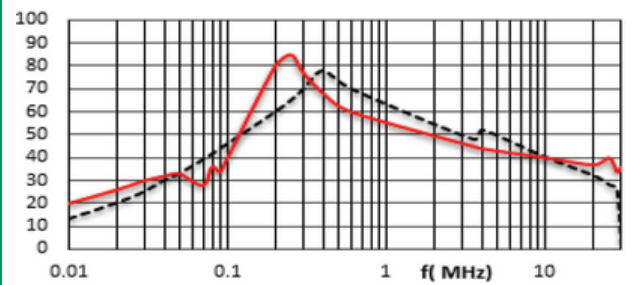

TMF3221-160-1-C9-RB1

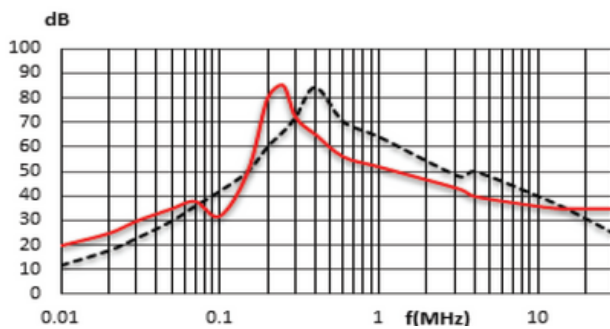

TMF3221-230-1-C9-RB1

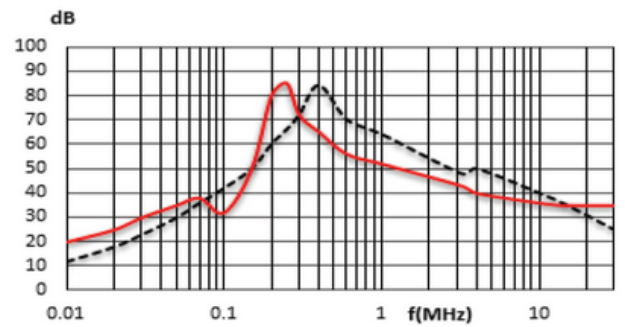

TMF3222-10-1-C11-RB1

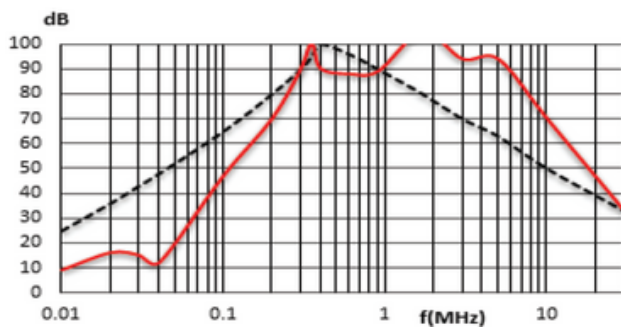

TMF3222-16-1-C11-RB1

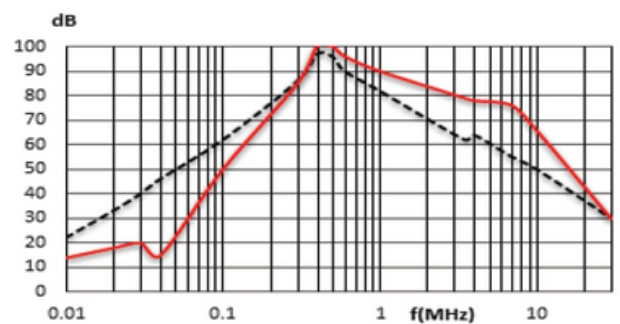

TMF3222-20-1-C11-RB1

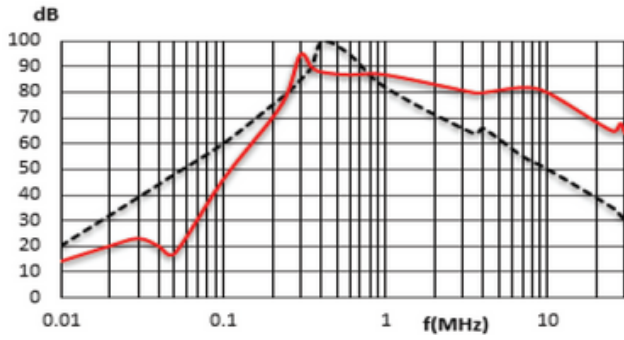

TMF3222-25-1-C11-RB1

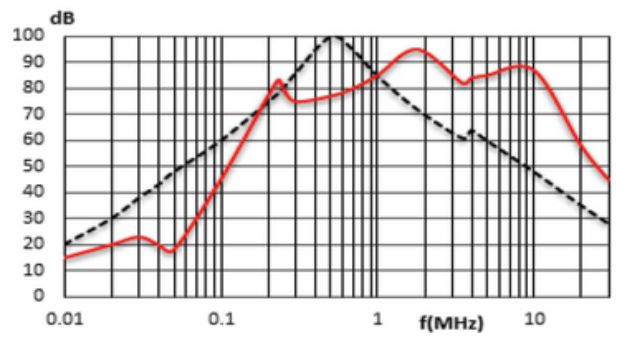

TMF3222-40-1-C11-RB1

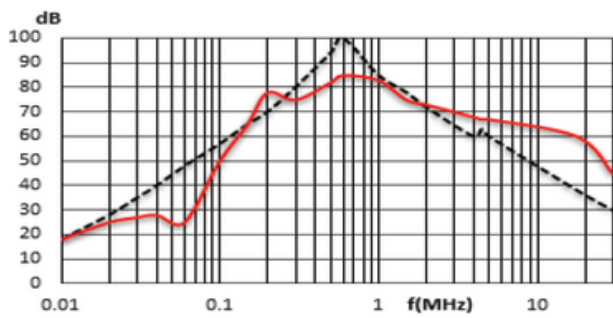

TMF3222-50-1-C11-RB1

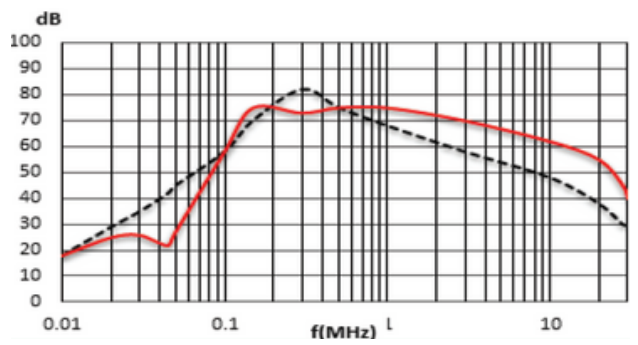

TMF3222-63-1-C11-RB1

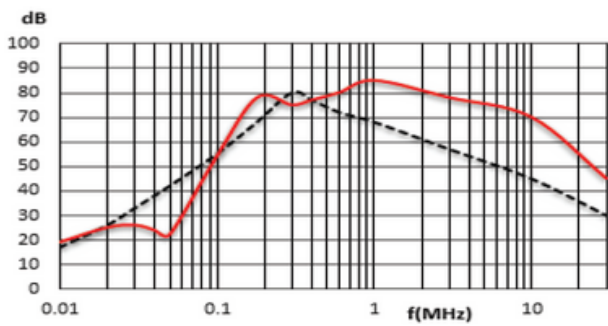

TMF3222-80-1-C11-RB1

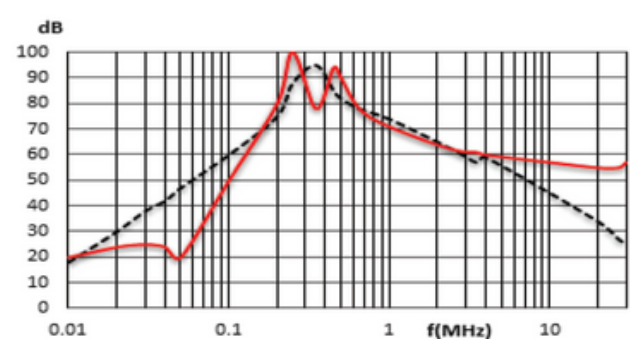

TMF3222-100-1-C11-RB1

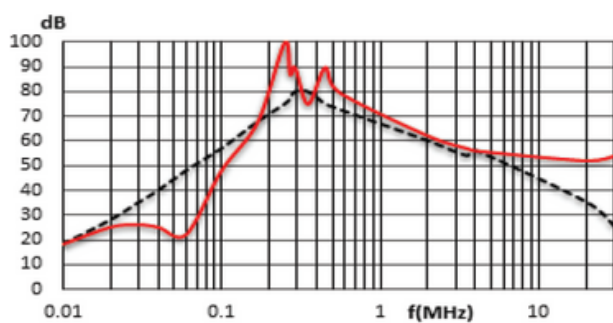

TMF3222-125-1-C11-RB1

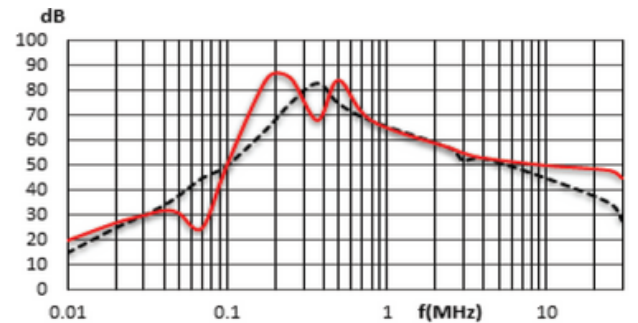

TMF3222-160-1-C11-RB1

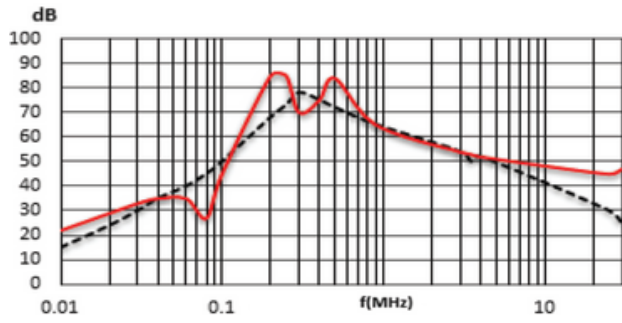

TMF3222-230-1-C11-RB1

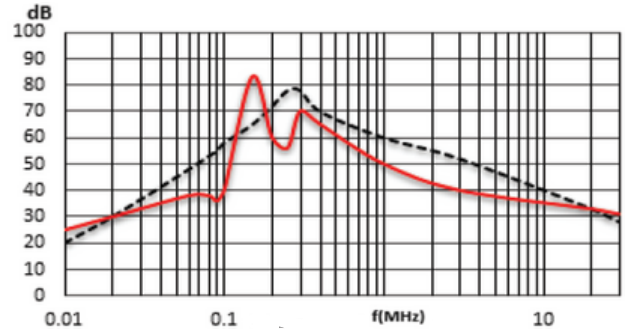

TMF3222-10-1-C11-RB1

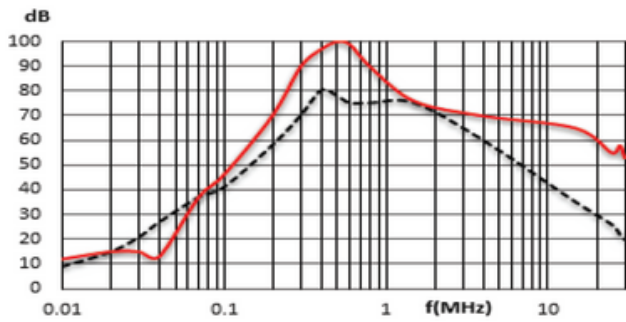

TMF3222-16-1-C11-RB1

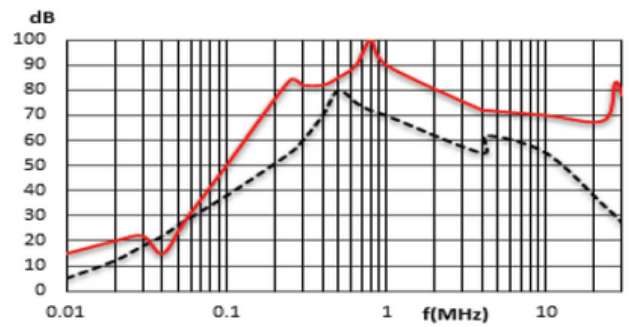

TMF3222-20-1-C11-RB1

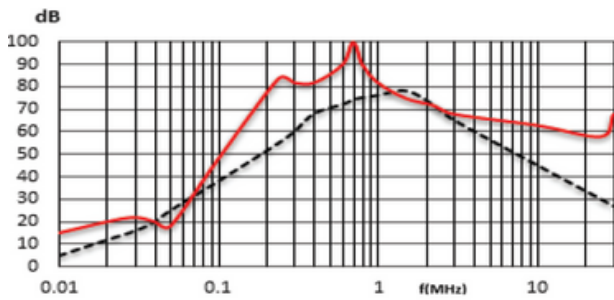

TMF3222-25-1-C11-RB1

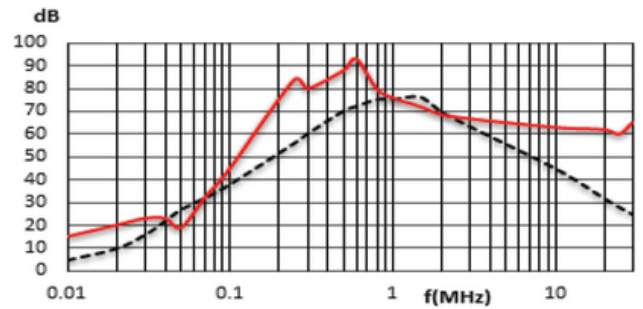

TMF3222-40-1-C3-RB1

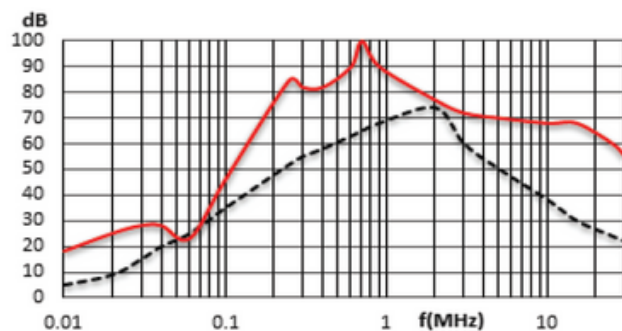

TMF3222-50-1-C3-RB1

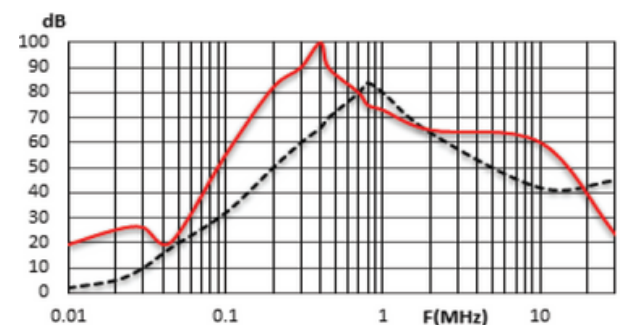

TMF3222-63-1-C3-RB1

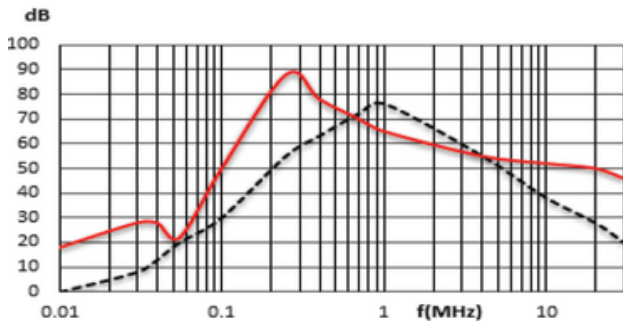

TMF3222-80-1-C3-RB1

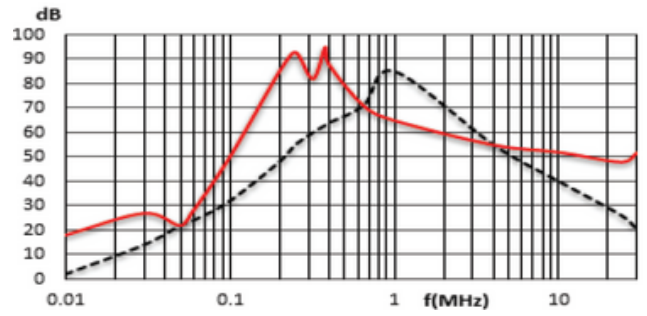

TMF3222-100-1-C3-RB1

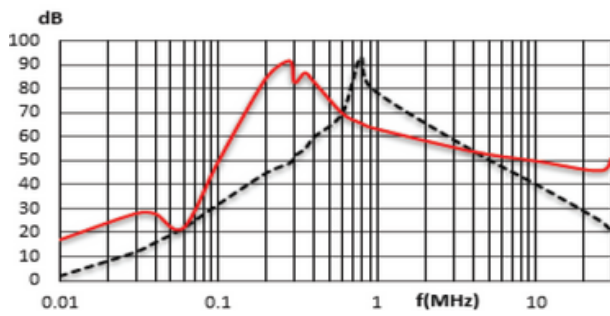

TMF3222-125-1-C3-RB1

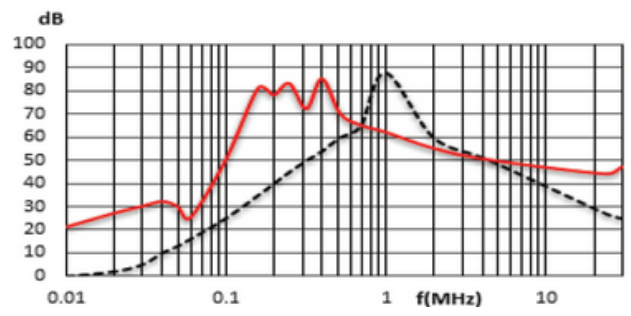

TMF3222-160-1-C3-RB1

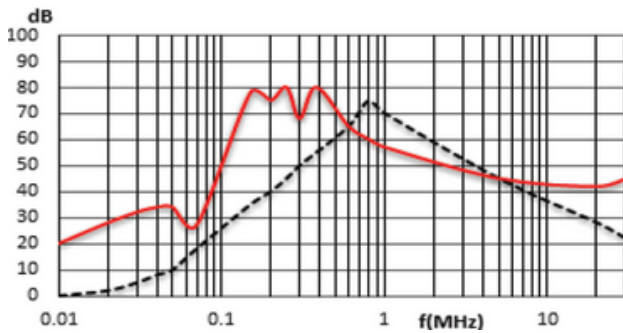

TMF3222-230-1-C3-RB1

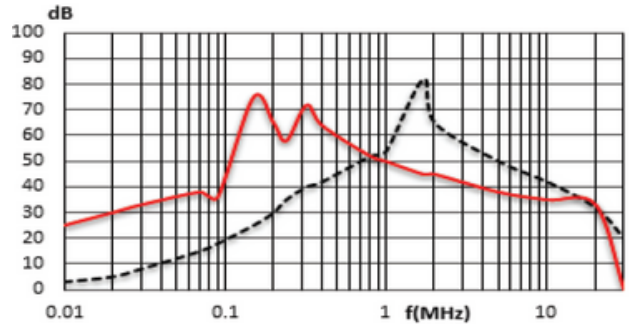

Mechanical Drawing

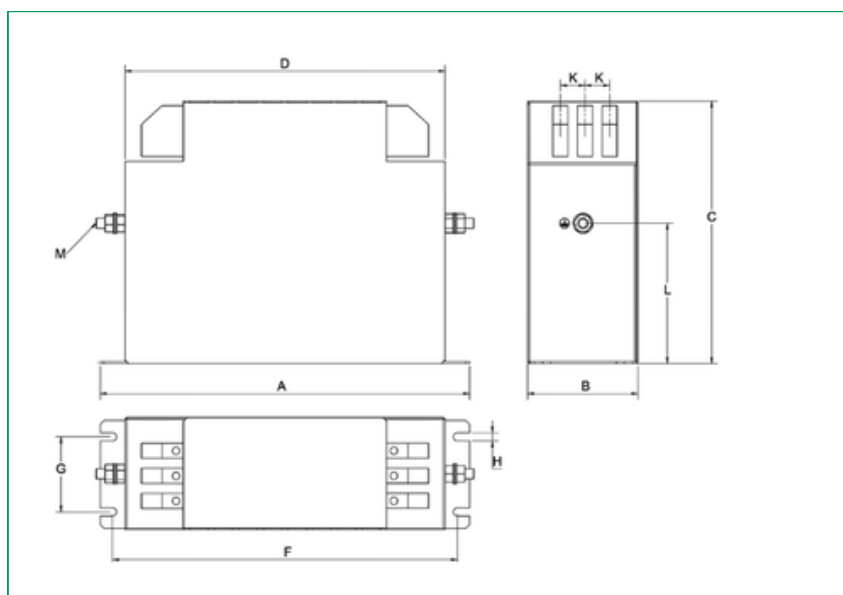

Connector Cross Sections

	6	16	35	50	95
Wire range	8 to 26 AWG	4 to 20 AWG	2 to 8 AWG	6 to 1/0 AWG	AWG 4/0
Stripping Length	9mm	16mm	19mm	24mm	27mm
Recommended torque (Nm)	1.19 to 1.46	2.48 to 2.82	2.48 to 2.82	4.29 to 4.51	3.5-6

Mechanical Dimensions

Enclosure	A	B	C	D	F	G	H	K	L±1	M
A	185	40	120	157	175	20	4.5	11	76	M5
B	195	45	140	164	180	25	5.4	11	93	M5
C	210	45	145	174	195	25	5.4	13	96	M5
D	235	50	168	207	220	30	5.4	13	115	M6
E	255	65	180	226	240	45	5.4	16	120	M6
F	290	80	205	250	270	50	6.5	22	110	M6
G	300	90	210	260	280	60	6.5	25	112	M8
H	310	100	225	270	290	70	6.5	28	110	M10
I	230	50	132	203	220	30	4.5	12.5	88	M5
J	230	55	159	198	215	35	5.4	13	112	M5
K	245	55	167	212	230	35	5.4	13	118	M5
L	265	60	191	237	250	40	5.4	13	135	M6
M	265	70	194	237	250	50	5.4	16	133	M6
N	310	95	220	270	290	65	6.5	22	125	M6
O	320	95	230	280	300	65	6.5	25	127	M8
P	330	100	240	290	310	70	6.5	30	127	M10
Q	180	40	112	153	170	20	4.5	11	68	M5
R	200	45	120	170	185	25	5.4	11	76	M5
S	205	45	132	173	190	25	5.4	13	83	M5
T	215	50	147	185	200	30	5.4	13	95	M6
U	220	65	180	186	205	45	5.4	16	120	M6
V	350	105	240	310	330	70	6.5	30.5	125	M10

All dimensions in mm ; Tolerance according: ISO 2768-C