



Approvals & Compliances



Features:

- Rated Current up to 30A
- Filters offer an optimized filter range for high performance AC & DC applications.
- High Conducted attenuation performance
- Various terminal options allow you to select the desired pulse connection style.
- Designed for easy and fast chassis mounting.

Applications:

- Power Systems
- Consumer goods
- Electronic Equipment
- Medical equipment
- Frequency convertors
- Electronic data processing equipment
- UPS/Inverters

DATA SHEET

SINGLE PHASE EMI FILTER - SMF2132

Description

These series of filters designed for motor and power drive systems which can provide superior attenuation performance and suppress conducted noise even when high interference level are present.



Technical Specifications:

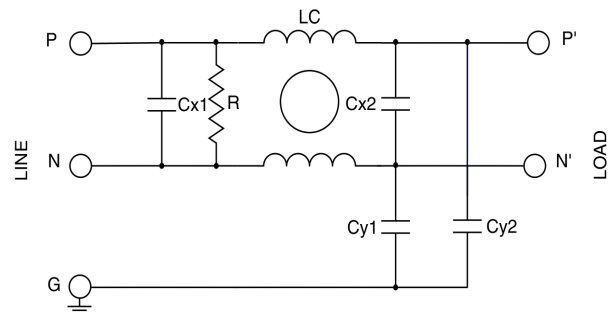

Maximum continuous operating voltage	:	250 VAC,50/60Hz (UL Approval) 250 VDC
Operating Frequency	:	DC to 400Hz
Current ratings	:	1A to 30A @40°C
High Potential test voltage	:	P to N 1414 VDC for 2 Sec P to G 2250 VDC for 2 Sec P to G 1500 VAC for 2 Sec (M Types)
Overload Capability	:	4 x rated current at switch on 1.5x rated current for 1 minute, once per hour
Design Corresponding to	:	UL 60939-3, CSA 22.2 No.8-13 and IEC60939-1&2
Flammability corresponding to	:	UL 94 V-0
Temperature range	:	-25°C to +100°C
Climatic Category	:	25/100/21
Protection category	:	IP20



Typical Circuit Diagram:





Ordering information:

STANDARD VERSION								
Model Number	Part Number	Current Rating @ 40°C (A)	Leakage current @ 250 VAC/50 Hz (mA)	Power loss @25°C / 50Hz (W)	Termination			Weight Approx. (g)
								
SMF2132-1-4	E108130-1	1	0.173	1	-4	-	-	70
SMF2132-1-5	E108130-2	1	0.173	1	-	-5	-	70
SMF2132-3-4	E108131-1	3	0.26	2.5	-4	-	-	110
SMF2132-3-5	E108131-2	3	0.26	2.5	-	-5	-	110
SMF2132-4-4	E108132-1	4	0.26	3	-4	-	-	120
SMF2132-4-5	E108132-2	4	0.26	3	-	-5	-	120
SMF2132-6-4	E108133-1	6	0.37	3.5	-4	-	-	120
SMF2132-6-5	E108133-2	6	0.37	3.5	-	-5	-	120
SMF2132-8-4	E108134-1	8	0.37	4	-4	-	-	200
SMF2132-8-5	E108134-2	8	0.37	4	-	-5	-	200
SMF2132-10-4	E108135-1	10	0.37	5.5	-4	-	-	200
SMF2132-10-5	E108135-2	10	0.37	5.5	-	-5	-	200
SMF2132-12-4	E108136-1	12	0.8	8	-4	-	-	270
SMF2132-12-5	E108136-2	12	0.8	8	-	-5	-	270
SMF2132-16-4	E108137-1	16	0.8	6.5	-4	-	-	270
SMF2132-16-5	E108137-2	16	0.8	6.5	-	-5	-	270
SMF2132-16-1	E108137-3	16	0.8	6.5	-	-	-1	270
SMF2132-20-4	E108138-1	20	0.8	5	-4	-	-	330
SMF2132-20-1	E108138-2	20	0.8	5	-	-	-1	330
SMF2132-30-1	E108139-1	30	0.8	6	-	-	-1	350

SAFETY VERSION								
Model Number	Part Number	Current Rating @ 40°C (A)	Leakage current @ 250 VAC/50 Hz (mA)	Power loss @25°C / 50Hz (W)	Termination			Weight Approx. (g)
								
SMF2132S-1-4	E108140-1	1	0.05	1	-4	-	-	70
SMF2132S-1-5	E108140-2	1	0.05	1	-	-5	-	70
SMF2132S-3-4	E108141-1	3	0.05	2.5	-4	-	-	110
SMF2132S-3-5	E108141-2	3	0.05	2.5	-	-5	-	110
SMF2132S-4-4	E108142-1	4	0.05	3	-4	-	-	120
SMF2132S-4-5	E108142-2	4	0.05	3	-	-5	-	120
SMF2132S-6-4	E108143-1	6	0.05	3.5	-4	-	-	120
SMF2132S-6-5	E108143-2	6	0.05	3.5	-	-5	-	120
SMF2132S-8-4	E108144-1	8	0.05	4	-4	-	-	200
SMF2132S-8-5	E108144-2	8	0.05	4	-	-5	-	200
SMF2132S-10-4	E108145-1	10	0.05	5.5	-4	-	-	200
SMF2132S-10-5	E108145-2	10	0.05	5.5	-	-5	-	200
SMF2132S-12-4	E108146-1	12	0.05	8	-4	-	-	270
SMF2132S-12-5	E108146-2	12	0.05	8	-	-5	-	270
SMF2132S-16-4	E108148-1	16	0.05	6.5	-4	-	-	270
SMF2132S-16-5	E108148-2	16	0.05	6.5	-	-5	-	270
SMF2132S-16-1	E108148-3	16	0.05	6.5	-	-	-1	270
SMF2132S-20-4	E108149-1	20	0.05	5	-4	-	-	330
SMF2132S-20-1	E108149-2	20	0.05	5	-	-	-1	330
SMF2132S-30-1	E108150-1	30	0.05	6	-	-	-1	350

MEDICAL VERSION								
Model Number	Part Number	Current Rating @ 40°C (A)	Leakage current @ 250 VAC/50 Hz (mA)	Power loss @25°C / 50Hz (W)	Termination			Weight Approx. (g)
								
SMF2132M-1-4	E108160-1	1	0	1	-4	-	-	70
SMF2132M-1-5	E108160-2	1	0	1	-	-5	-	70
SMF2132M-3-4	E108161-1	3	0	2.5	-4	-	-	110
SMF2132M-3-5	E108161-2	3	0	2.5	-	-5	-	110
SMF2132M-4-4	E108162-1	4	0	3	-4	-	-	120
SMF2132M-4-5	E108162-2	4	0	3	-	-5	-	120
SMF2132M-6-4	E108163-1	6	0	3.5	-4	-	-	120
SMF2132M-6-5	E108163-2	6	0	3.5	-	-5	-	120
SMF2132M-8-4	E108164-1	8	0	4	-4	-	-	200
SMF2132M-8-5	E108164-2	8	0	4	-	-5	-	200
SMF2132M-10-4	E108165-1	10	0	5.5	-4	-	-	200
SMF2132M-10-5	E108165-2	10	0	5.5	-	-5	-	200
SMF2132M-12-4	E108166-1	12	0	8	-4	-	-	270
SMF2132M-12-5	E108166-2	12	0	8	-	-5	-	270
SMF2132M-16-4	E108167-1	16	0	6.5	-4	-	-	270
SMF2132M-16-5	E108167-2	16	0	6.5	-	-5	-	270
SMF2132M-16-1	E108167-3	16	0	6.5	-	-	-1	270
SMF2132M-20-4	E108168-1	20	0	5	-4	-	-	330
SMF2132M-20-1	E108168-2	20	0	5	-	-	-1	330
SMF2132M-30-1	E108169-1	30	0	6	-	-	-1	350

ENHANCED VERSION								
Model Number	Part Number	Current Rating @ 40°C (A)	Leakage current @ 250 VAC/50 Hz (mA)	Power loss @25°C / 50Hz (W)	Termination		Weight Approx. (g)	
								
SMF2132N-1-4	E108170-1	1	5.35	1	-4	-	70	
SMF2132N-3-4	E108171-1	3	3.69	2.5	-4	-	110	
SMF2132N-4-4	E108172-1	4	3.69	3	-4	-	120	
SMF2132N-6-4	E108173-1	6	3.69	3.5	-4	-	120	
SMF2132N-8-4	E108174-1	8	5.35	4	-4	-	200	
SMF2132N-10-4	E108175-1	10	5.35	5.5	-4	-	200	
SMF2132N-12-4	E108176-1	12	5.35	8	-4	-	270	
SMF2132N-16-4	E108177-1	16	3.69	6.5	-4	-	270	
SMF2132N-16-1	E108177-2	16	3.69	6.5	-	-1	270	
SMF2132N-20-4	E108178-1	20	3.69	5	-4	-	330	
SMF2132N-20-1	E108178-2	20	3.69	5	-	-1	330	
SMF2132N-30-1	E108179-1	30	3.69	6	-	-1	350	

Note : Maximum leakage current is according to IEC 60939-3 under normal AC operating conditions. The worst leakage current could double the value if the neutral is interrupted.

Insertion Loss : Common mode _____ Differential Mode

Per CISPR 17; C=50 Ω/50 Ω D=50 Ω/50 Ω

1A Standard Version

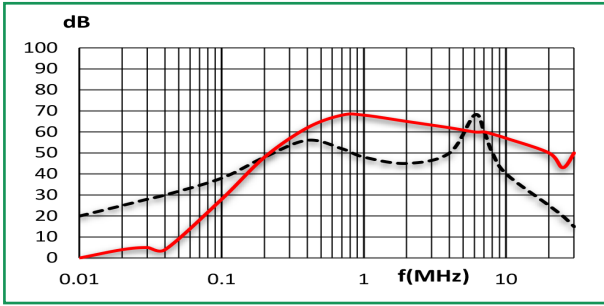

Safety Version

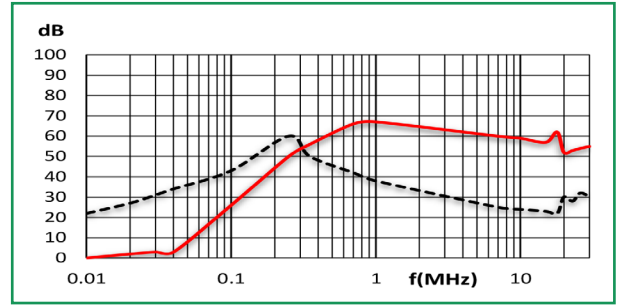

Medical Version

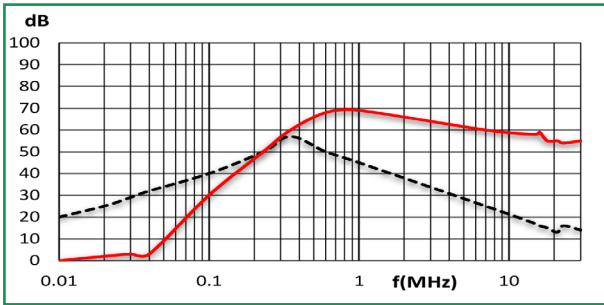

Enhanced Performance

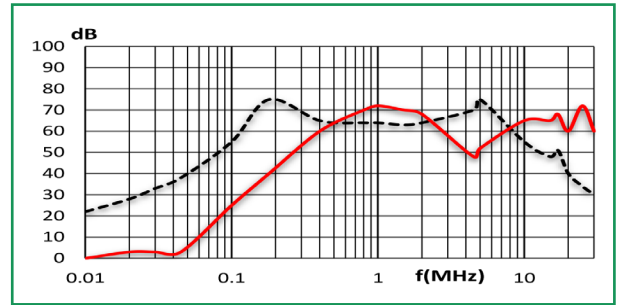

3A Standard Version

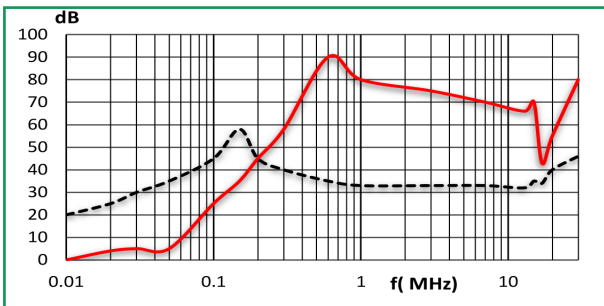

Safety Version

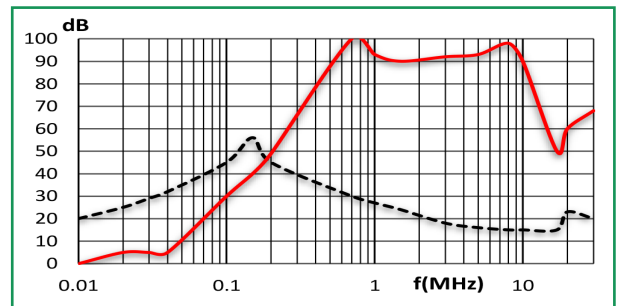

Medical Version

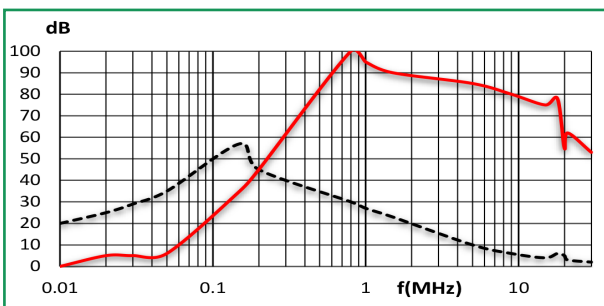

Enhanced Performance

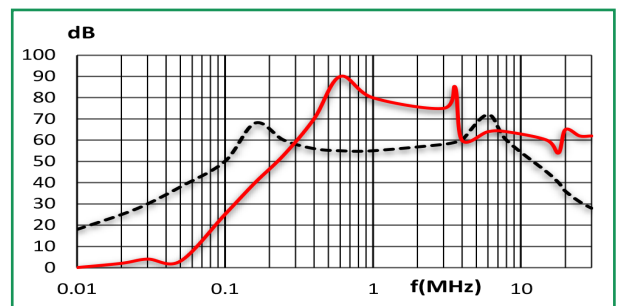

4A Standard Version

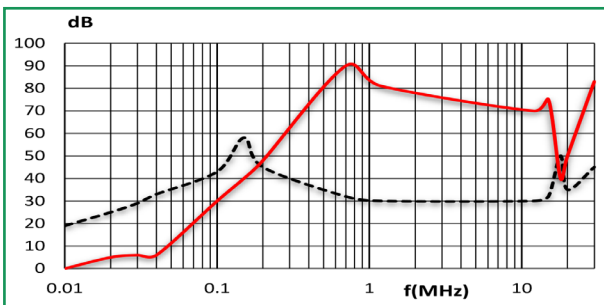

Safety Version

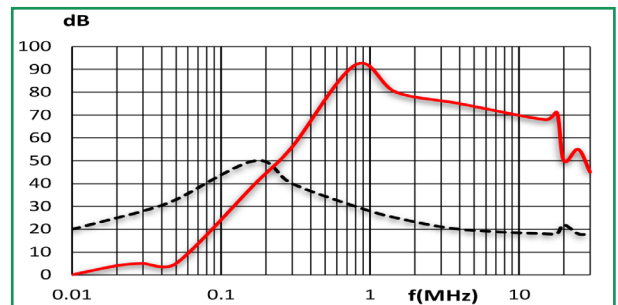

Medical Version

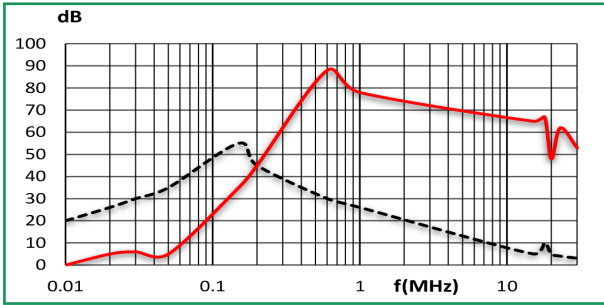

Enhanced Performance

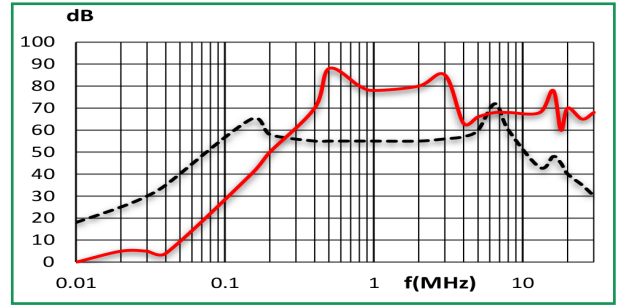

6A Standard Version

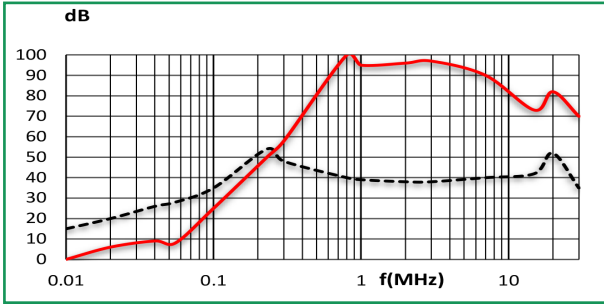

Safety Version

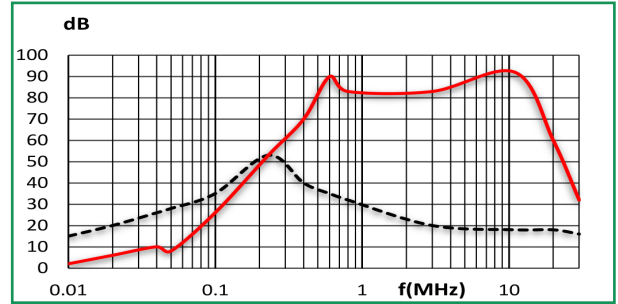

Medical Version

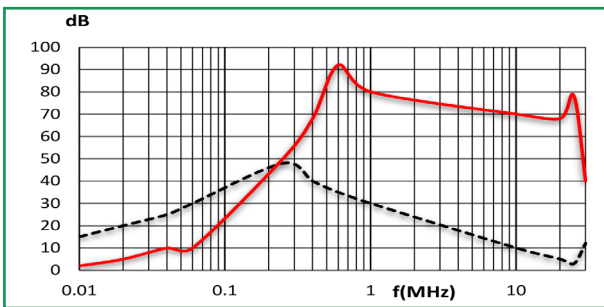

Enhanced Performance

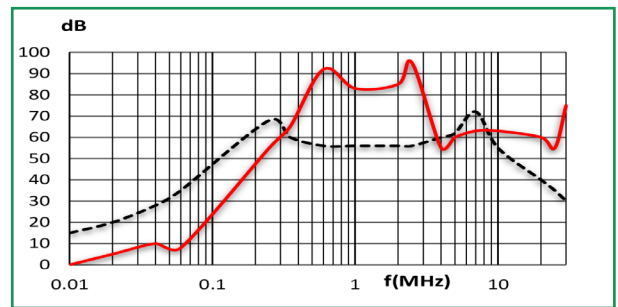

8A Standard Version

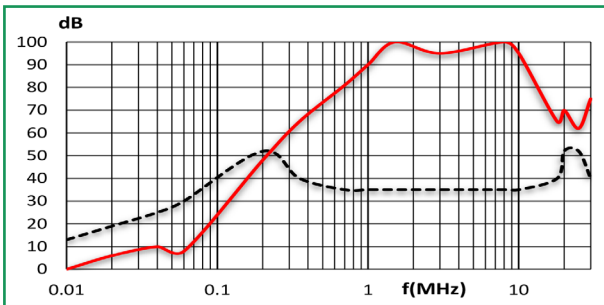

Safety Version

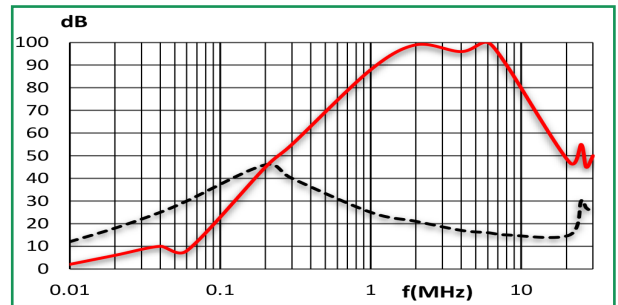

Medical Version

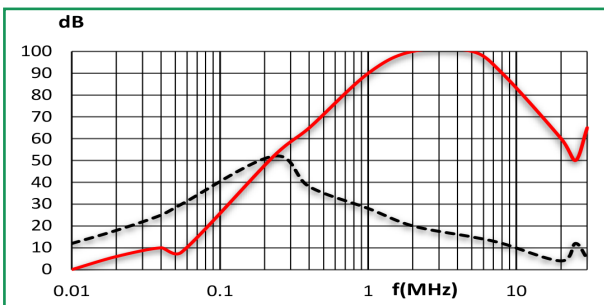

Enhanced Performance

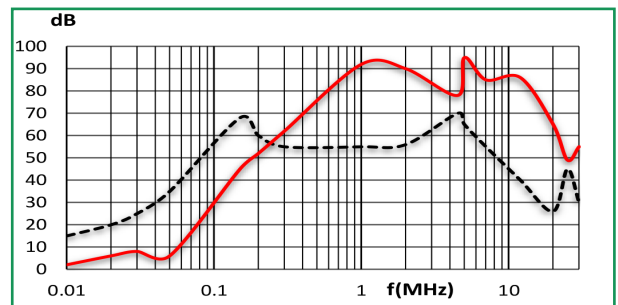

10A

Standard Version

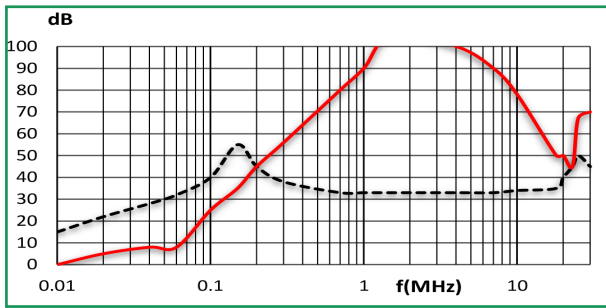

Safety Version

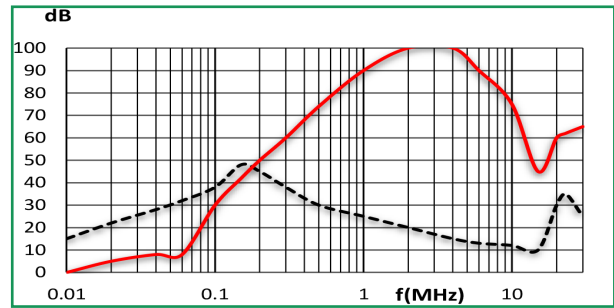

Medical Version

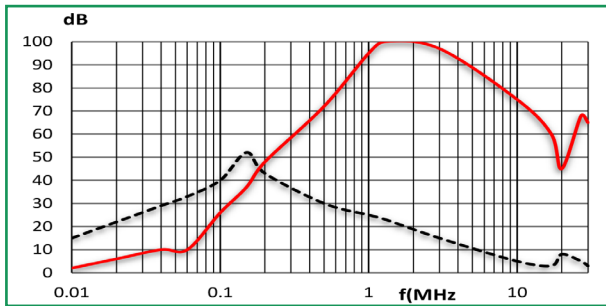

Enhanced Performance

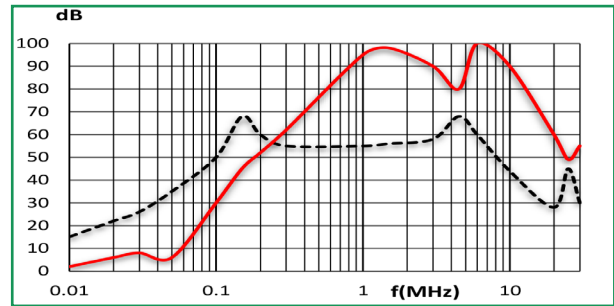

12A

Standard Version

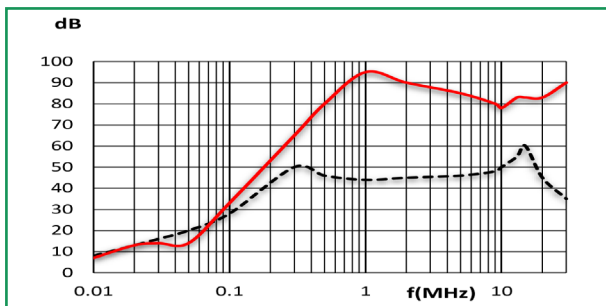

Safety Version

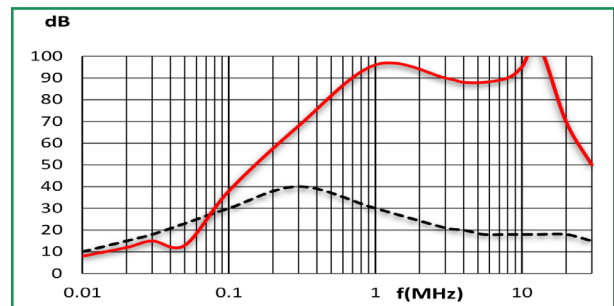

Medical Version

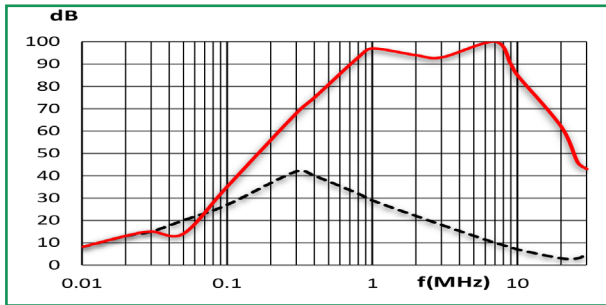

Enhanced Performance

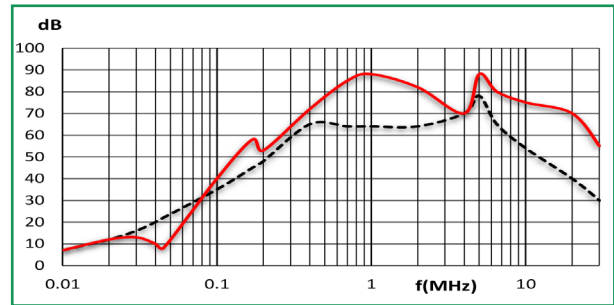

16A

Standard Version

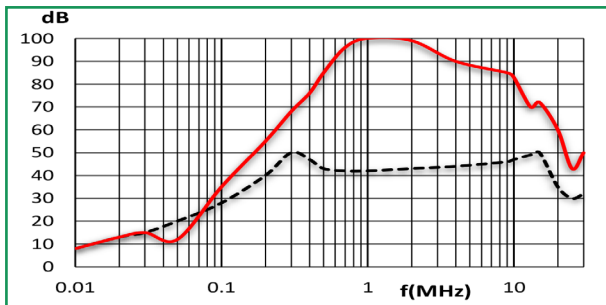

Safety Version

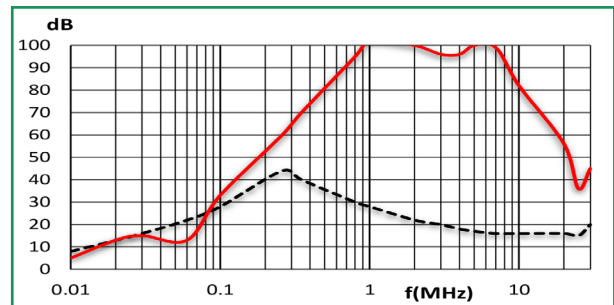

Medical Version

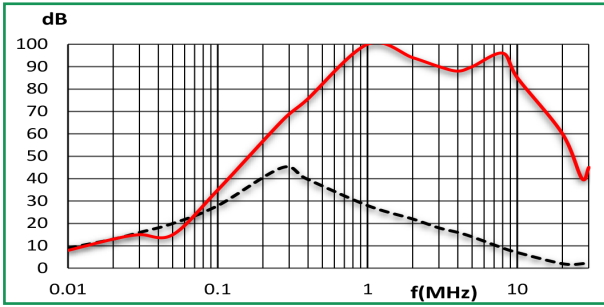

Enhanced Performance

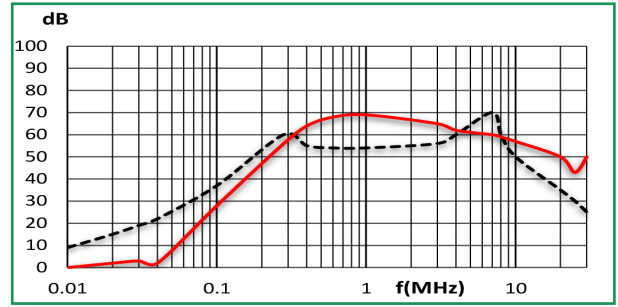

20A

Standard Version

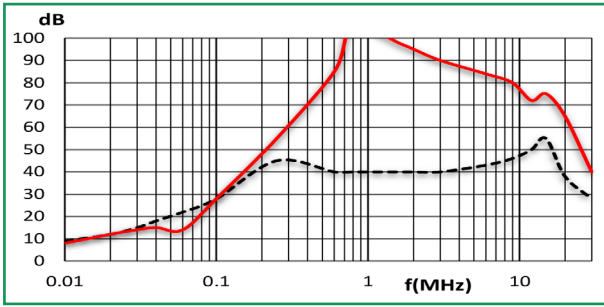

Safety Version

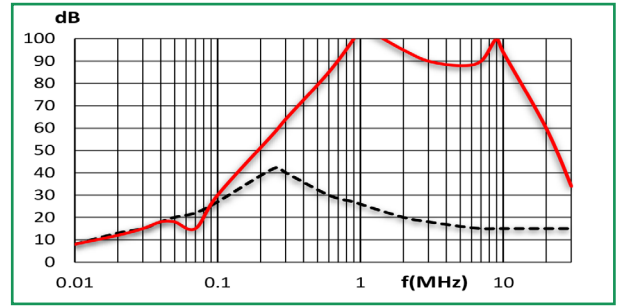

Medical Version

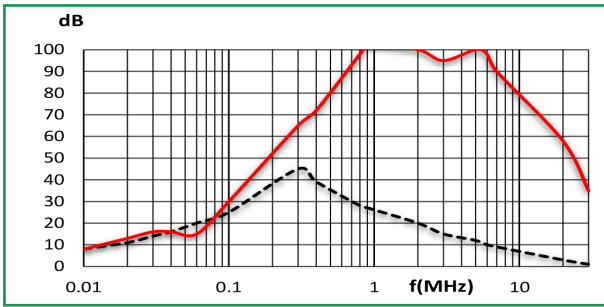

Enhanced Performance

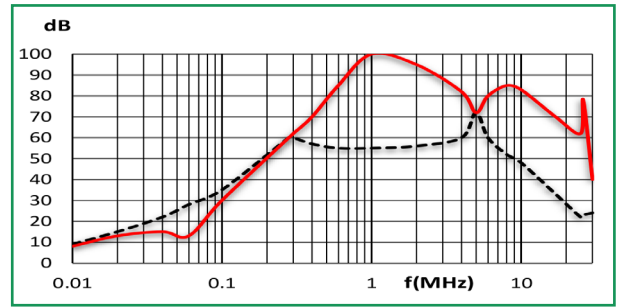

30A

Standard Version

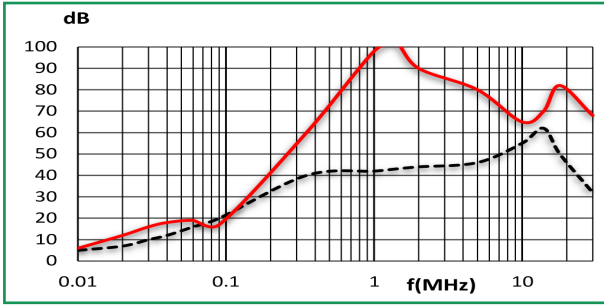

Safety Version

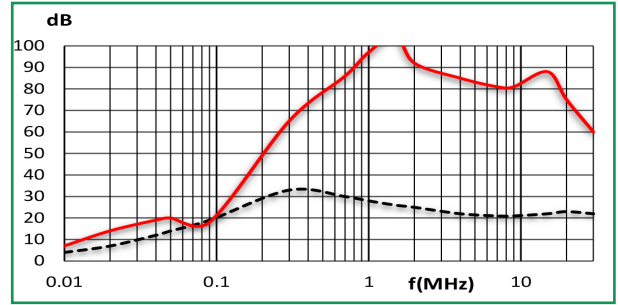

Medical Version

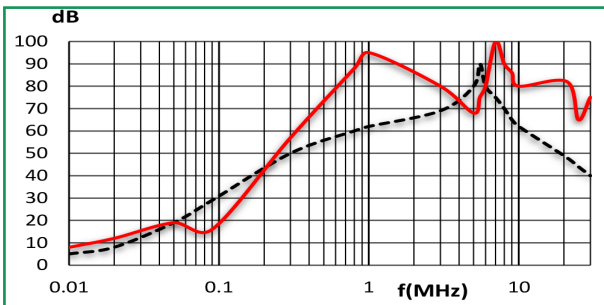

Enhanced Performance

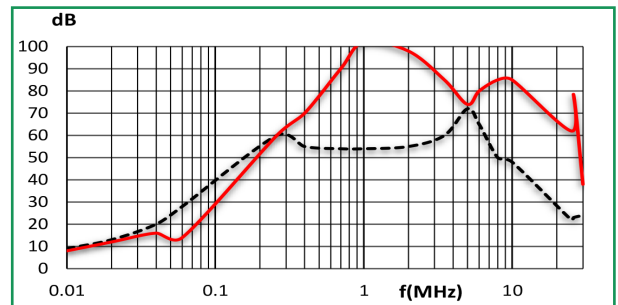

Mechanical Drawing:

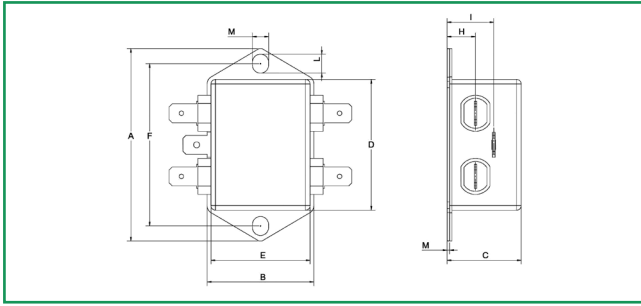

Connection style -04, 1A types

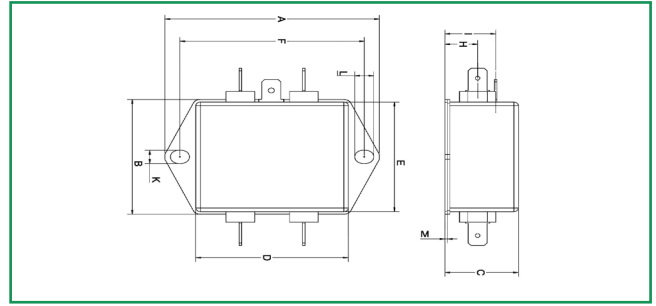

Connection style -04, 3A to 6A types

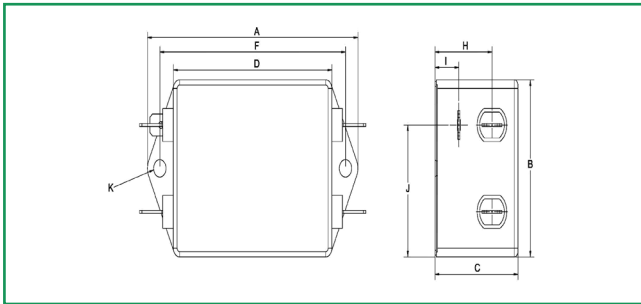

Connection style -04, 8A to 12A types

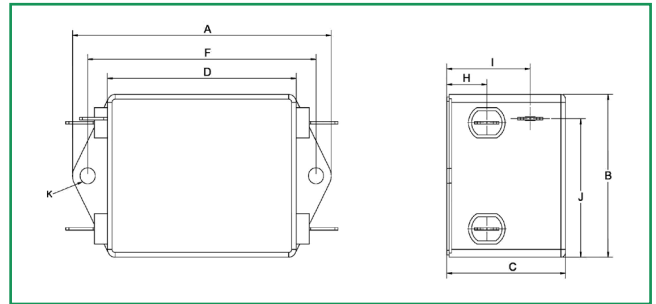

Connection style -04, 16A to 30A types

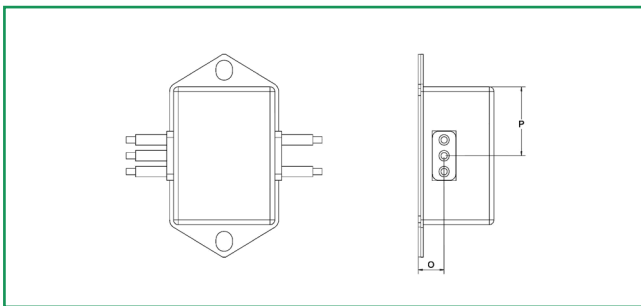

**Connection style -05, 1A to 6A types
(same dimensions as style -04)**

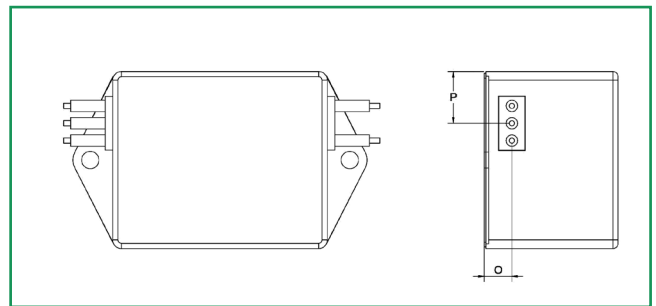

**Connection style -05, 8A to 16A types
(same dimensions as style -04)**

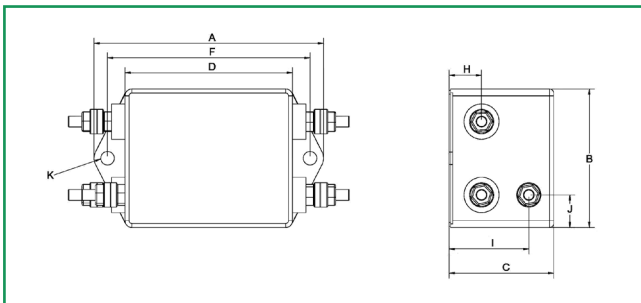

Connection style -01 16A to 30 A types

Mechanical dimensions:

	1A	3A	4A	6A	8A	10A	12A	16A	20A	30A
A	64±1	71±1	71±1	71±1	85±1	85±1	85±1	85±1	85±1	85±1
B	35±1	46.6±1	46.6±1	46.6±1	51±1	51±1	51±1	51±1	51±1	51±1
C	24.3±1	22.3±1	22.3±1	22.3±1	32.5±1	32.5±1	32.5±1	39±1	39±1	39±1
D	43.5±1	50.5±1	50.5±1	50.5±1	64±1	64±1	64±1	62±1	62±1	62±1
E	32.5	44.5	44.5	44.5	-	-	-	-	-	-
F	54	61	61	61	75	75	75	75	75	75
H	9.3	10.8	10.8	10.8	21.5	21.5	21.5	13	13	13
I	15.3	16.8	16.8	16.8	9	9	9	27.5	27.5	27.5
K	5.3	5.3	5.3	5.3	5	5	5	5	5	5
L	6.3	6.3	6.3	6.3	-	-	-	-	-	-
M	0.8	0.8	0.8	0.8	0.8	0.8	0.8	0.8	0.8	0.8
Connection Style-04	-	-	-	-	-	-	-	-	-	-
N	6.3x0.8	6.3X0.8	6.3X0.8	6.3X0.8	6.3X0.8	6.3X0.8	6.3X0.8	6.3X0.8	6.3X0.8	6.3X0.8
Connection Style-05	-	-	-	-	-	-	-	-	-	-
O	8.3	8.3	8.3	8.3	8.3	8.3	8.3	8.3	-	-
P	21.8	14	14	14	14.9	14.9	14.9	14.9	-	-
AWG Type Wire	AWG 20	AWG 20	AWG 20	AWG 18	AWG 18	AWG 18	AWG 16	AWG 16	-	-
Wire Length	140	140	140	140	140	140	140	140	-	-
Connection Style-01	-	-	-	-	-	-	-	-	-	-
N	-	-	-	-	-	-	-	M4	M4	M4
Recommended torque (Nm)	-	-	-	-	-	-	-	1.2-1.3	1.2-1.3	1.2-1.3
Earth terminal Recommended torque (Nm)	-	-	-	-	-	-	-	1.5-1.7	1.5-1.7	1.5-1.7

All dimensions in mm;Tolerance according: ISO 2768-c