

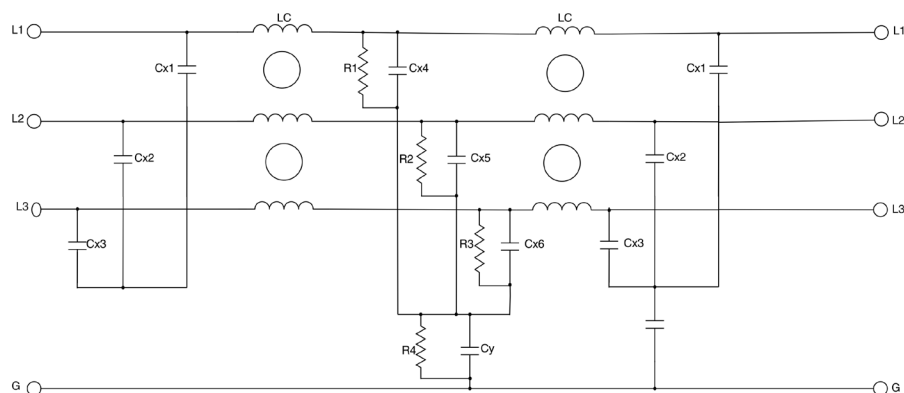

**Features:**

- Superior Performance
- Compact
- Low leakage versions available
- Book Shelf Mounting

**Applications:**

- IT power Distribution network
- Three Phase Drives
- Renewable energy Systems
- Process Automation Equipments
- Energy Conversion Devices

**DATA SHEET**
**MF 423-3-3D-BS-HV**
**Typical circuit Diagram**

**Technical Specifications:**

Operating Rated Voltage	: 750VAC / 760VAC
Rated Currents	: 7A to 180A@40°C
Operating Frequency	: 50 / 60 Hz
High Potential test voltage	: L to G 3535Vdc ; L to L 3268Vdc
Overload Capacity	: 135% of Rated current for 15 min
Design Corresponding to	: UL 60939-3 and CSA 22.2 No 8-13
Flammability Corresponding to	: UL 94 V-0
Operating temperature	: -25°C to 85°C
Climatic Category	: 25/85/21

## Selection Table

Model Number	Part Number	Rated Current @40°C	Leakage Current (mA)	Termination	Weight (Kgs)
MF423-3-3D-BS-HV	E102578-1	7A	10	16	4.5
MF423-3-3D-BS-HV	E102579-1	10A	10	16	4.5
MF423-3-3D-BS-HV	E102580-1	16A	10	16	4.5
MF423-3-3D-BS-HV	E102581-1	20A	10	16	5
MF423-3-3D-BS-HV	E102582-1	25A	10	16	5.5
MF423-3-3D-BS-HV	E102583-1	30A	10	16	5.5
MF423-3-3D-BS-HV	E102584-1	42A	10	16	5.5
MF423-3-3D-BS-HV	E102585-1	55A	10	16	5.8
MF423-3-3D-BS-HV	E102586-1	63A	12	16	8
MF423-3-3D-BS-HV	E102587-1	75A	12	16	8
MF423-3-3D-BS-HV	E102588-1	80A	12	16	8
MF423-3-3D-BS-HV	E102589-1	90A	12	25	8
MF423-3-3D-BS-HV	E102590-1	100A	12	25	10.5
MF423-3-3D-BS-HV	E102591-1	130A	12	50	15
MF423-3-3D-BS-HV	E102592-1	150A	12	50	16
MF423-3-3D-BS-HV	E102593-1	180A	12	95	17

## Connector Details

	16	25	50	95
Wire Section-Flexible(mm2)	0.5-16	10-25	16-50	35-95
Recommended Torque (Nm)	2-2.3	4-4.5	6-8	15-20

## Mechanical Drawing:

### 7A-10A

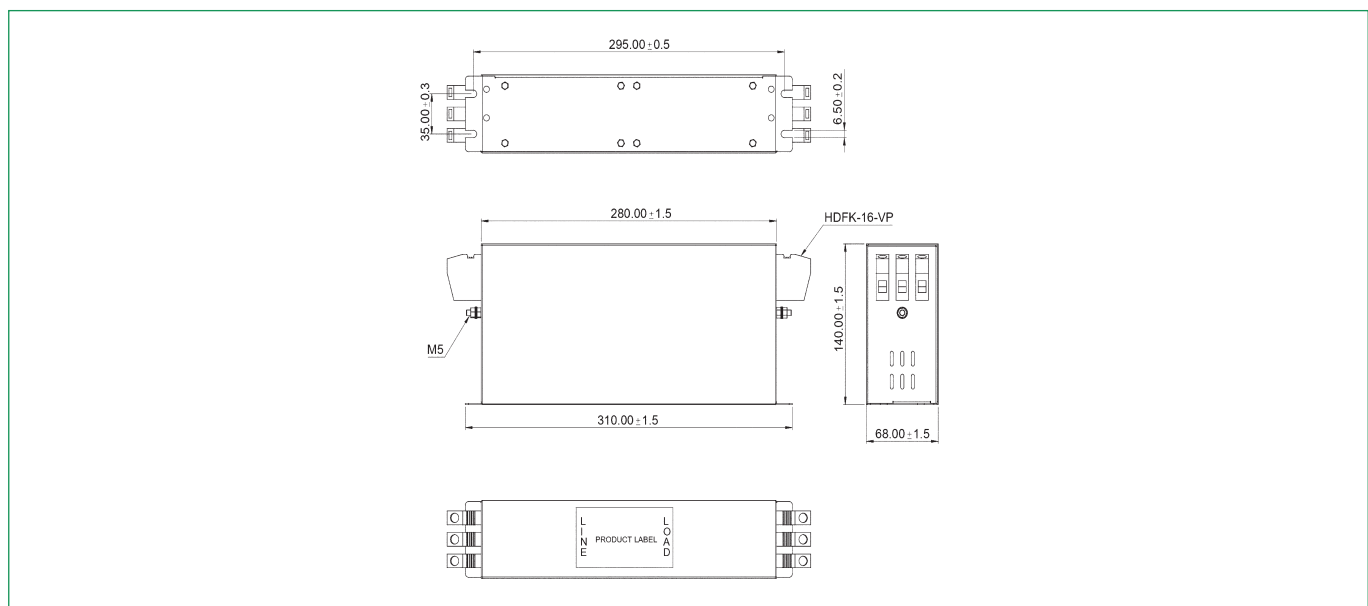

## 16A-42A

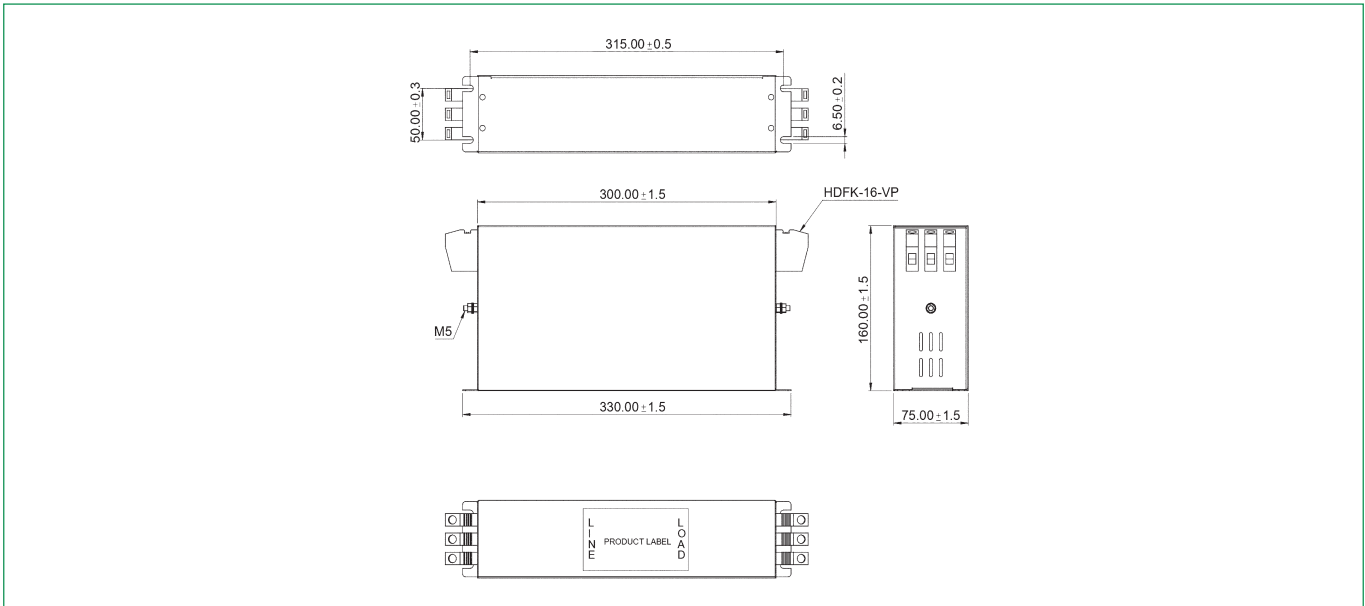

## 55A

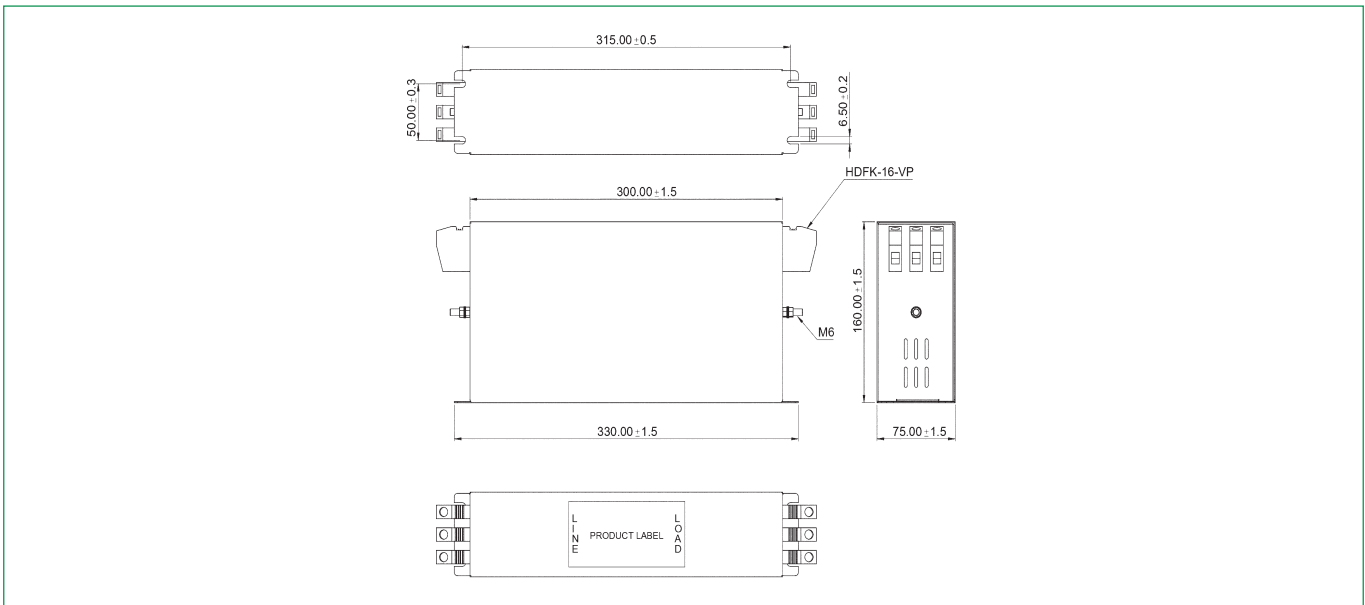

## 63A-80A

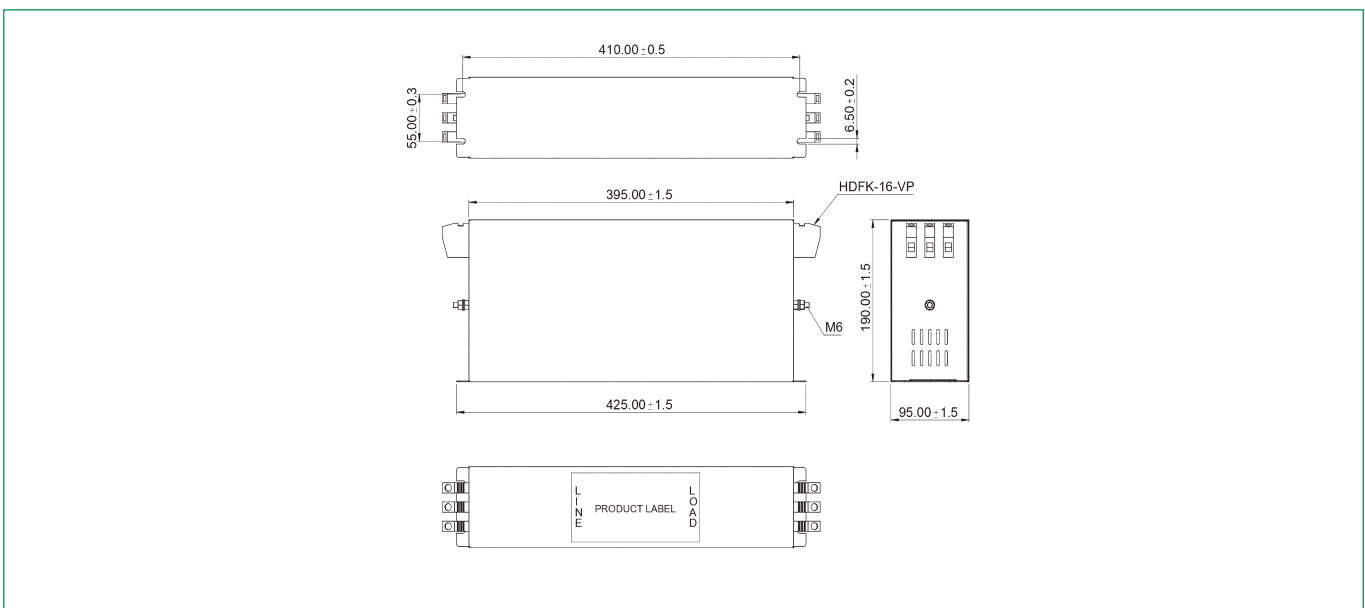

# 90A

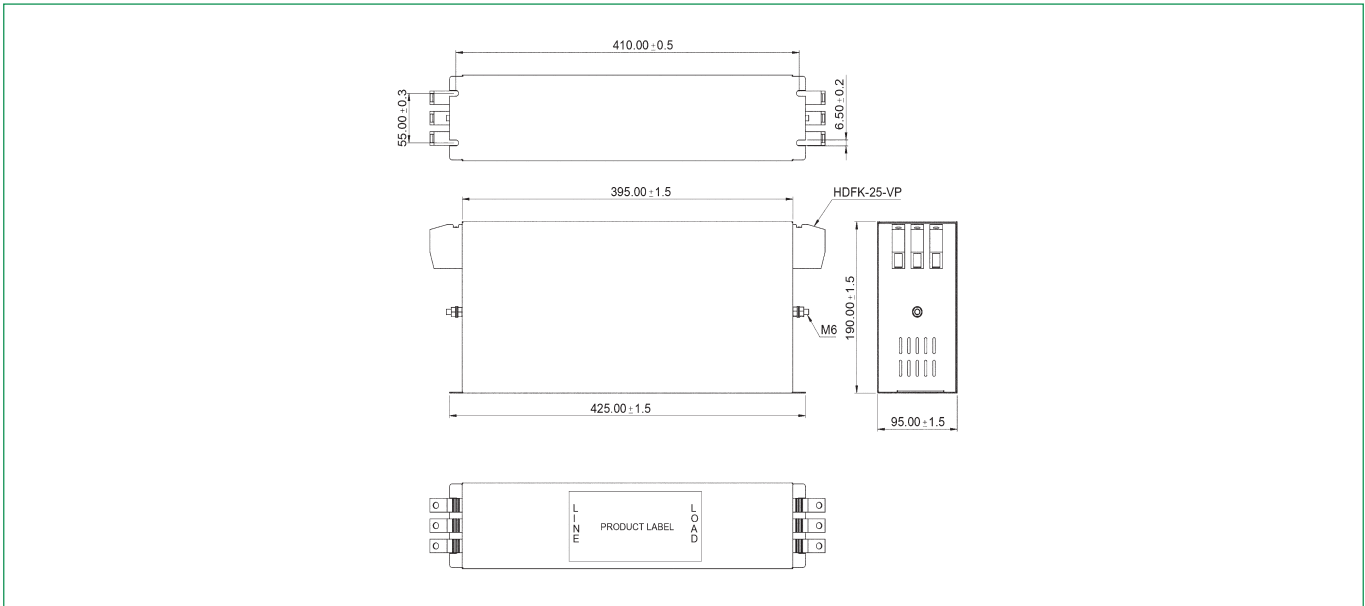

# 100A

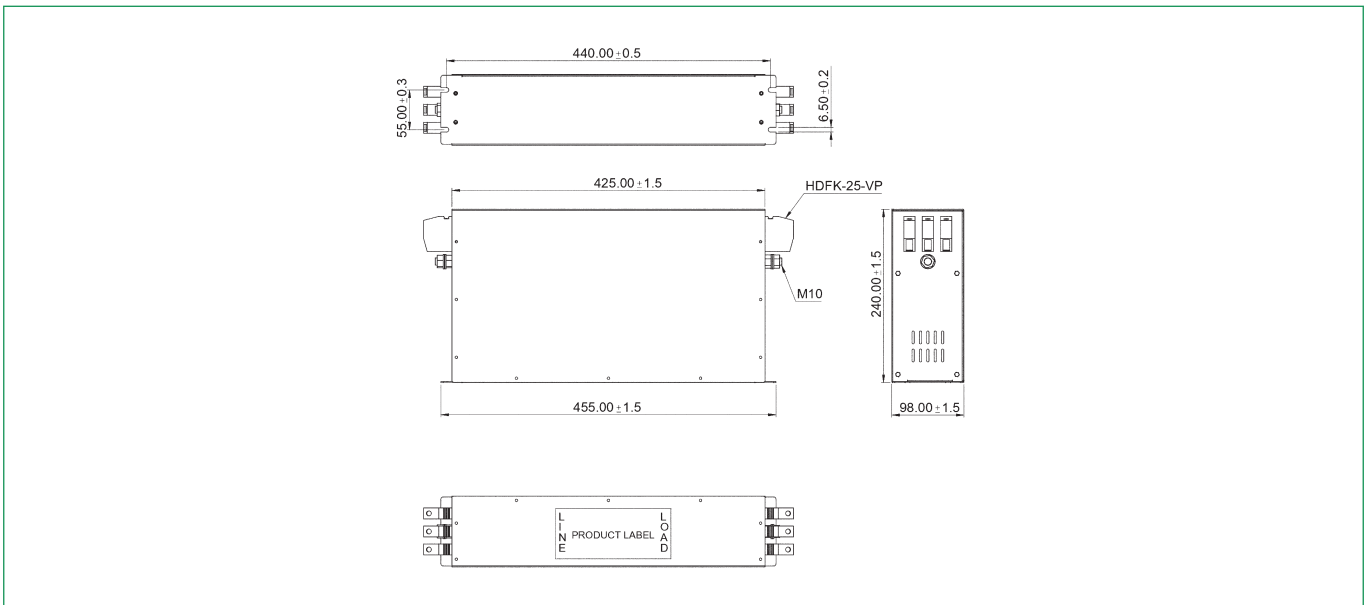

# 130A-150A

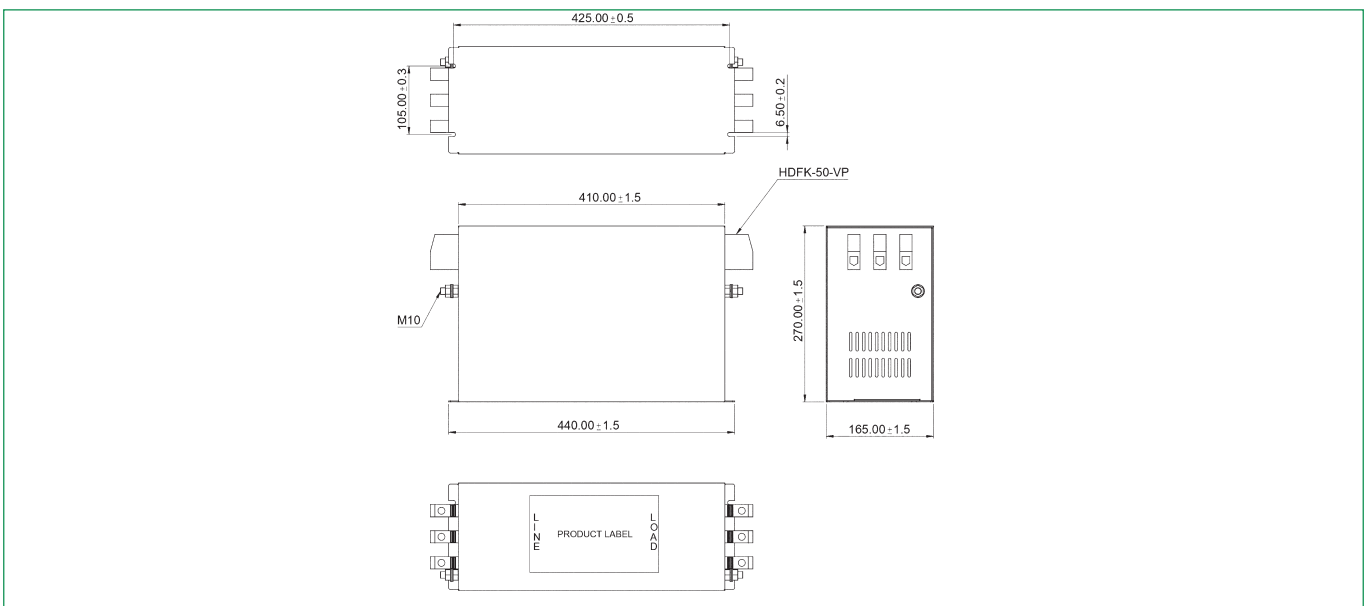

180A

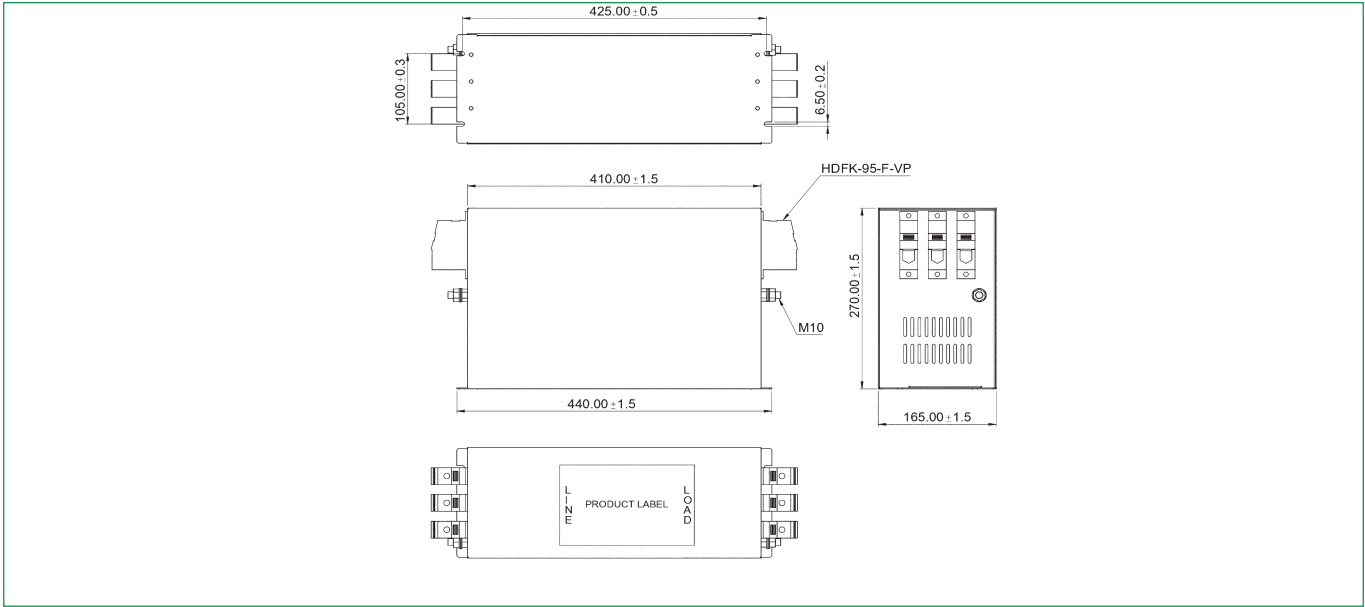

Insertion Loss : ..... Common mode \_\_\_\_\_ Differential Mode  
 Per CISPR 17; DM=50/50 sym; CM=50/50 asym

7A

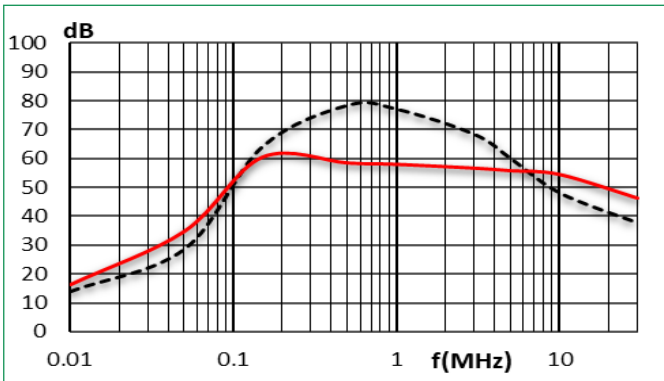

10A

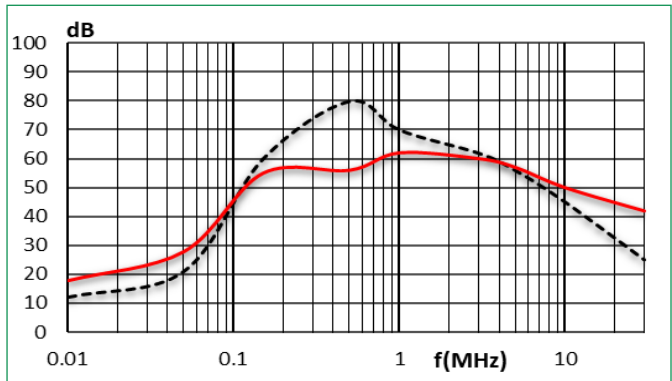

16A

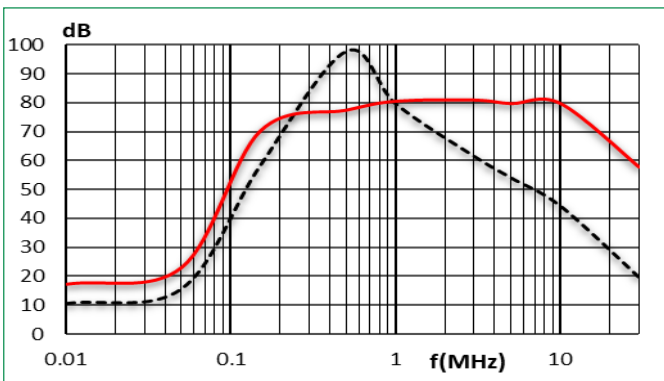

20A

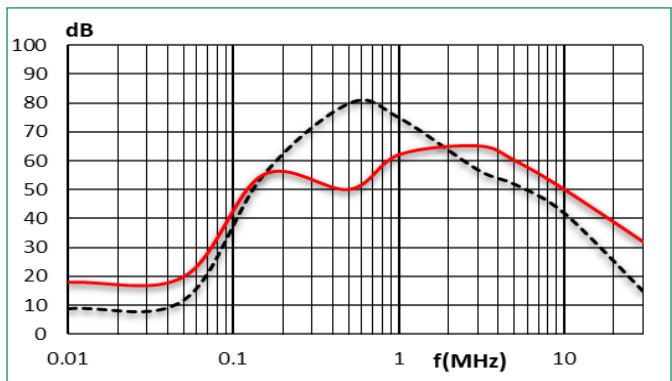

25A

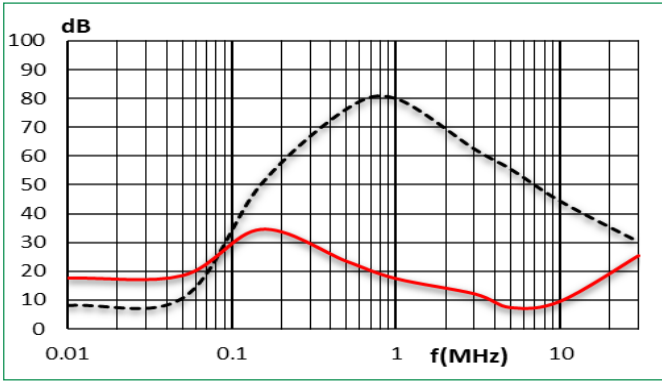

30A

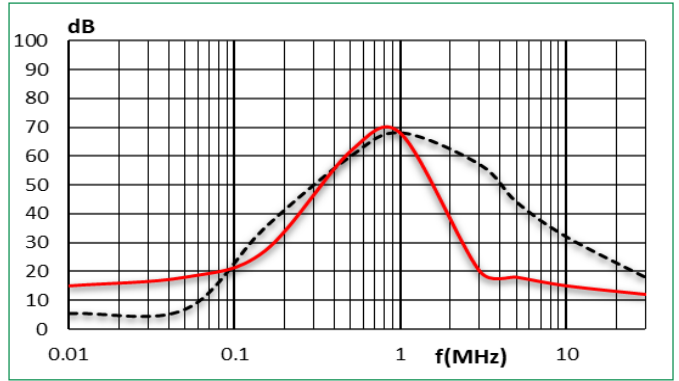

42A

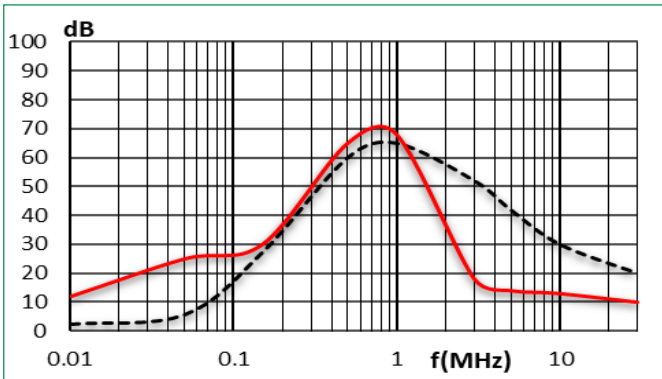

55A

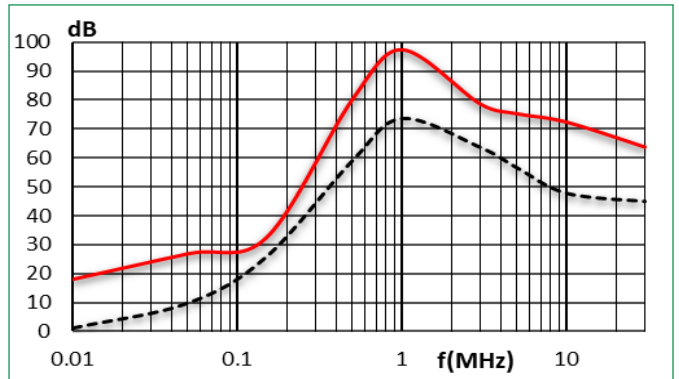

63A

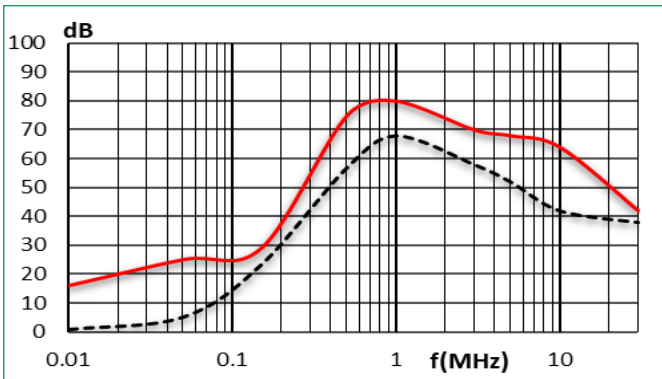

75A

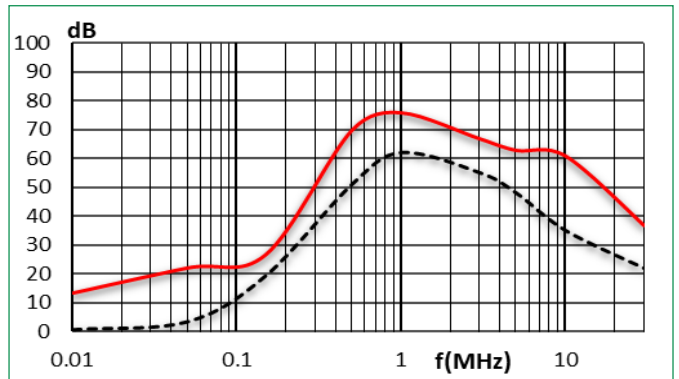

80A

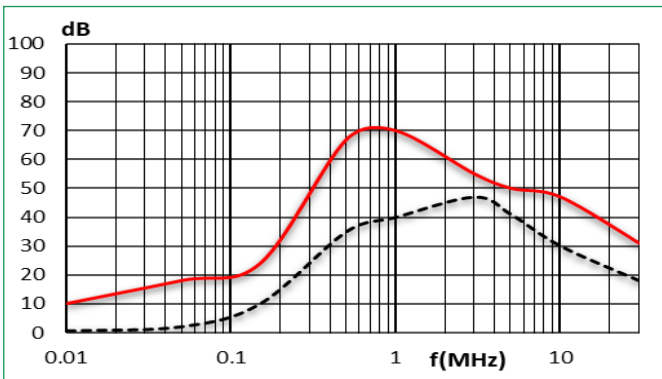

90A

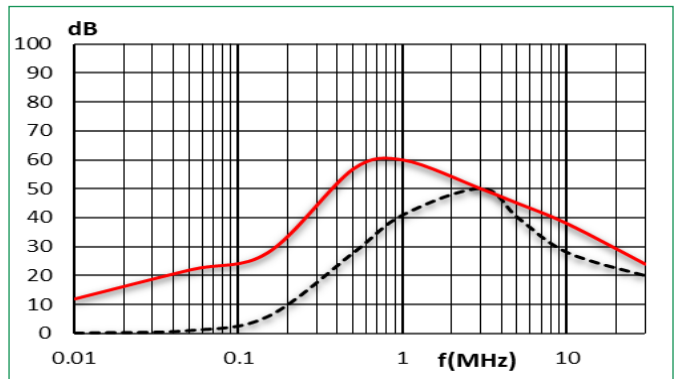

### 100A

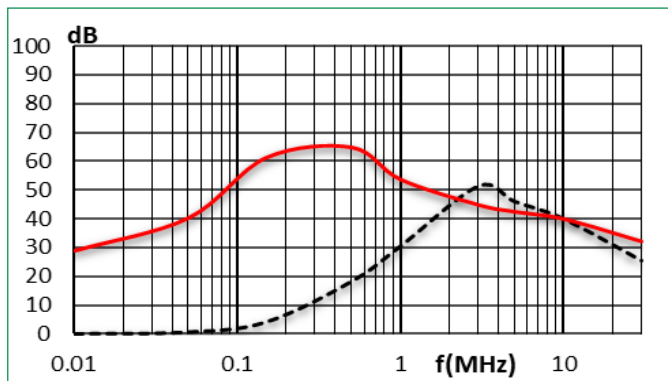

### 130A

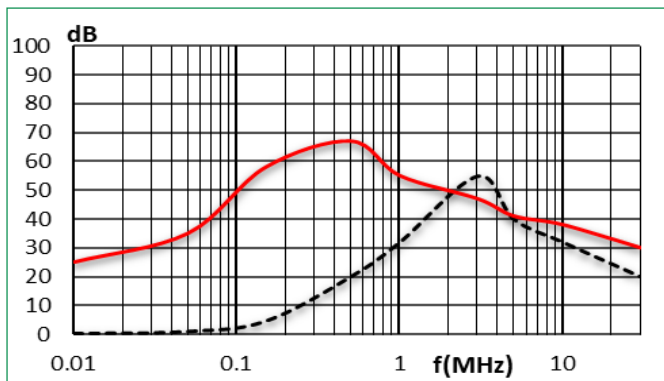

### 150A

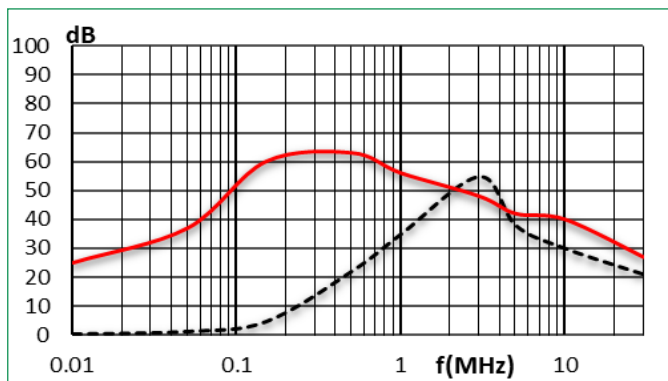

### 180A

